

# GE UNIR

- I CENTRALE DI COMANDO PER CANCELLI A DUE ANTE.
- GB CONTROL UNIT FOR TWO-LEAF GATES.
- F CENTRALE DE COMMANDE POUR PORTAILS À 2 BATTANTS.
- E UNIDAD DE CONTROL PARA CANCELAS DE DOS HOJAS.



Security  
Kala.ir

فروشگاه تجهیزات حفاظتی و امنیتی



ISTRUZIONI E AVVERTENZE PER L'INSTALLAZIONE, L'USO E LA MANUTENZIONE.  
INSTRUCTIONS AND WARNINGS FOR INSTALLATION, USE AND MAINTENANCE.  
INSTRUCTIONS ET CONSEILS POUR L'INSTALLATION, L'UTILISATION ET L'ENTRETIEN.  
INSTRUCCIONES Y ADVERTENCIAS PARA LA INSTALACIÓN, EL USO Y EL MANTENIMIENTO.



INSTALLAZIONE STANDARD  
 STANDARD INSTALLATION  
 INSTALLATION STANDARD  
 INSTALACIÓN ESTÁNDAR

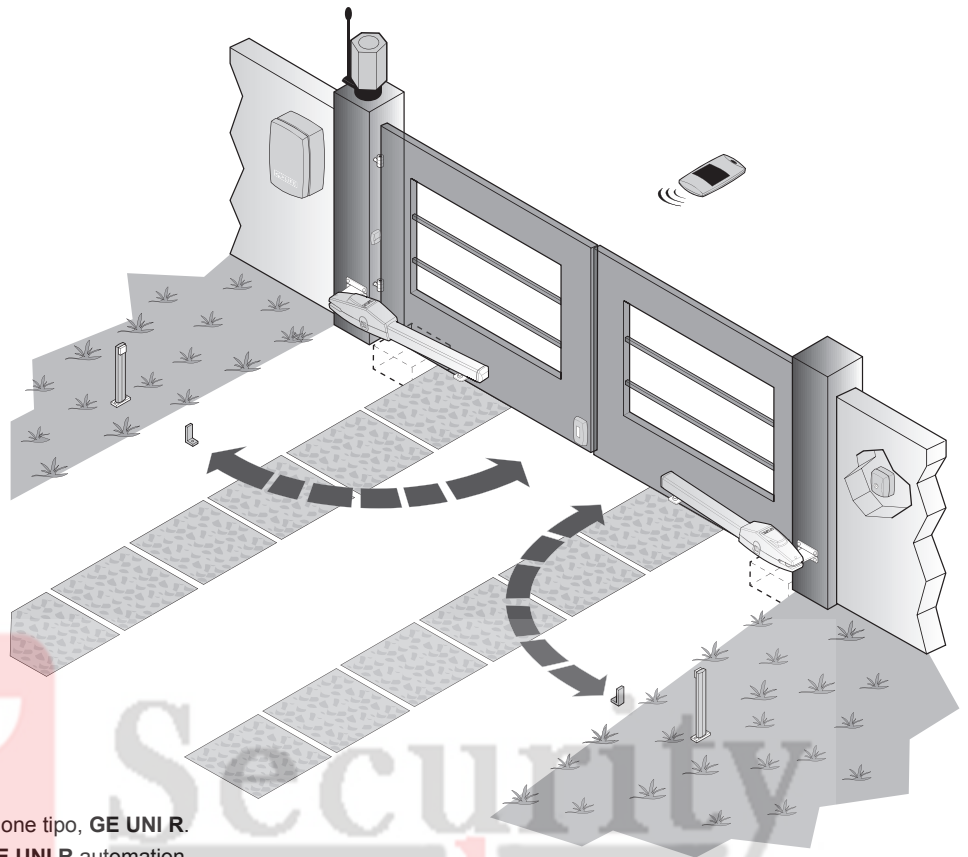

Tab. 1: Componenti e dispositivi di un'automazione tipo, **GE UNI R**.

Tab. 1: Components and devices of a typical **GE UNI R** automation.

Tab. 1: Composants et dispositifs d'un automatisme type, **GE UNI R**.

Tab. 1: Componentes y dispositivos de un automatismo tipo, **GE UNI R**.

Tab. 2: Descrizione contenuto scatola centralina **GE UNI R**.

Tab. 2: Description of the content of a **GE UNI R** control unit pack.

Tab. 2: Description contenu boîtier centrale **GE UNI R**.

Tab. 2: Descripción del contenido de la caja del cuadro de control **GE UNI R**.

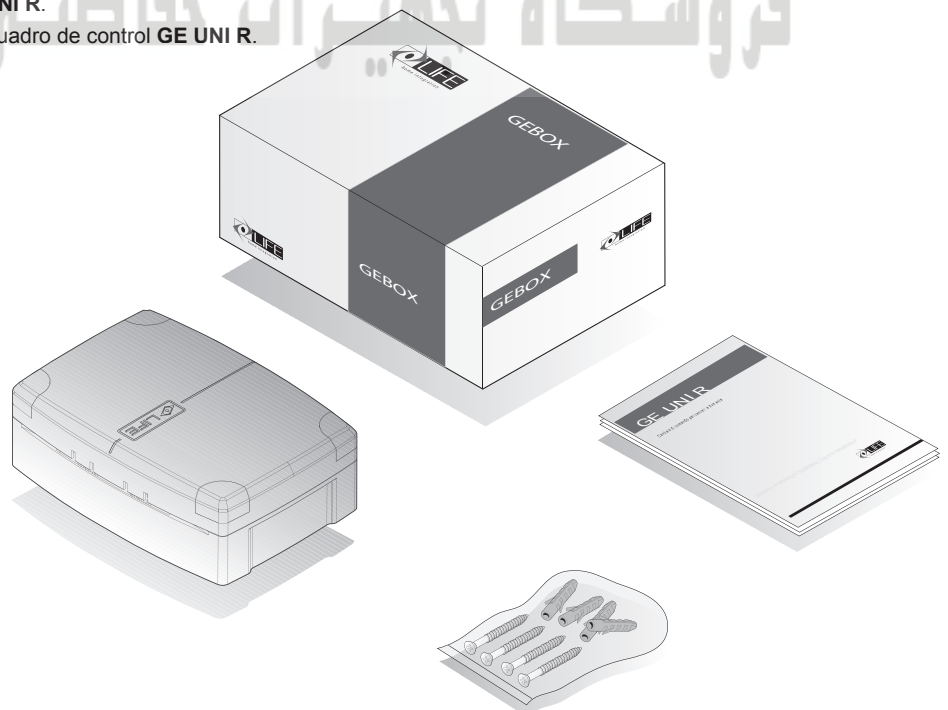

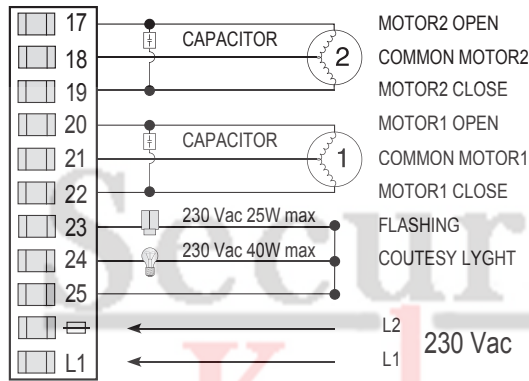
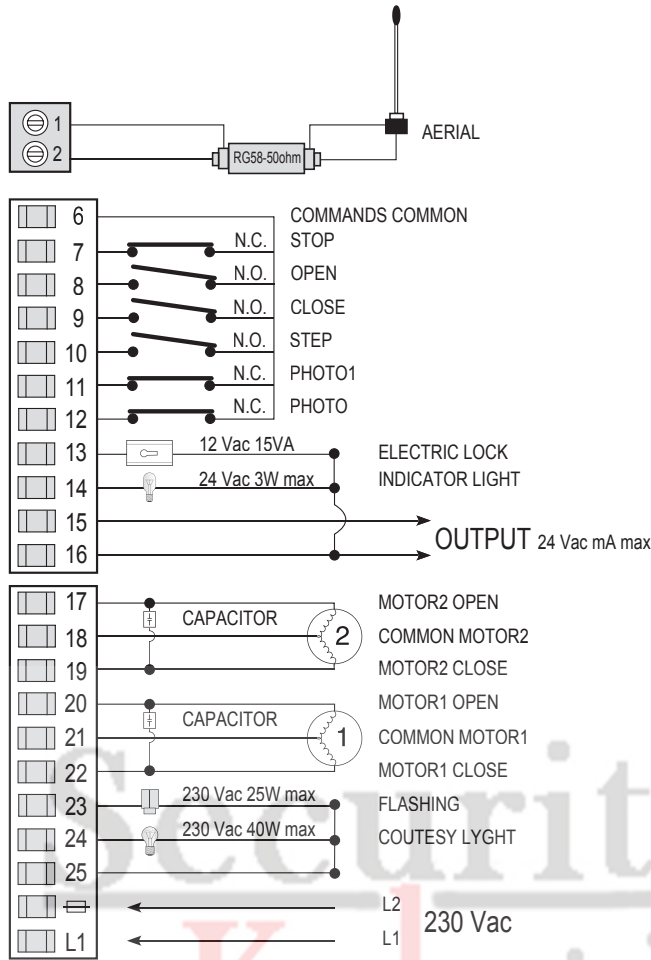
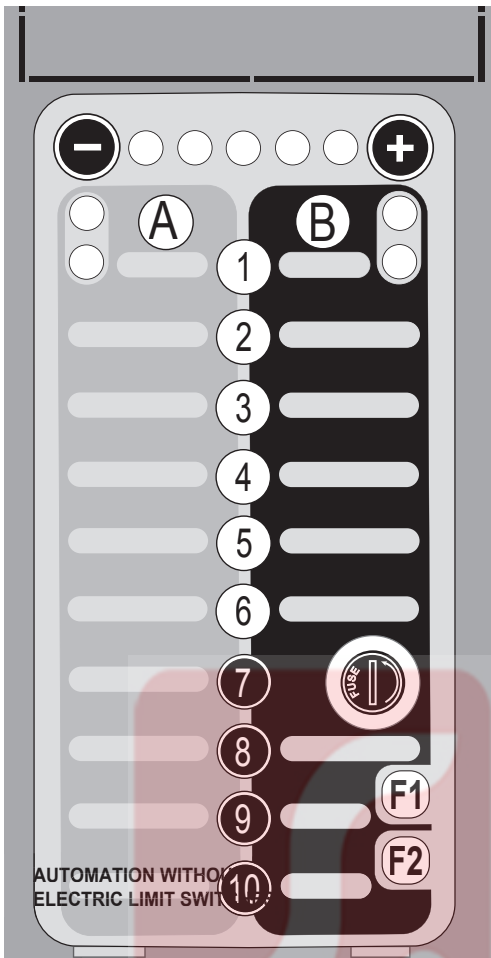

SCHEMA ELETTRICO  
ELECTRICAL SYSTEM  
INSTALLATION ELECTRIQUE  
EQUIPO ELÉCTRICO

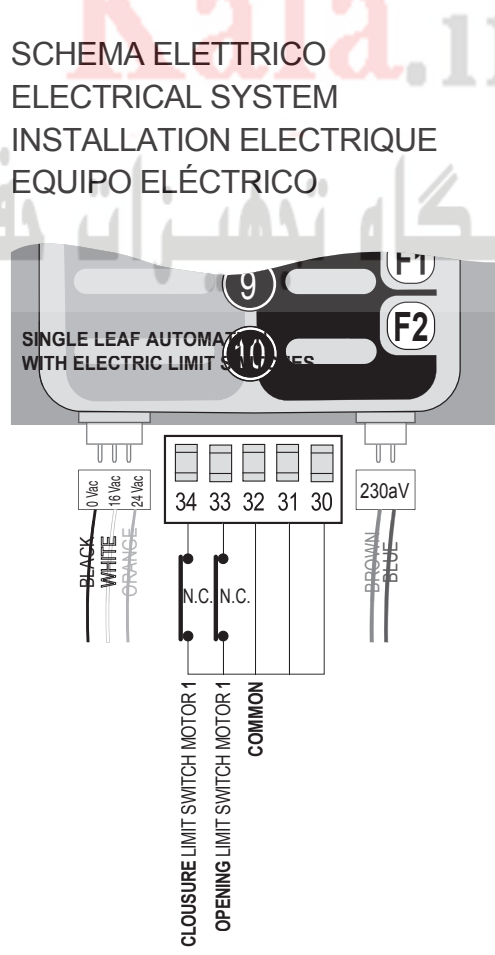
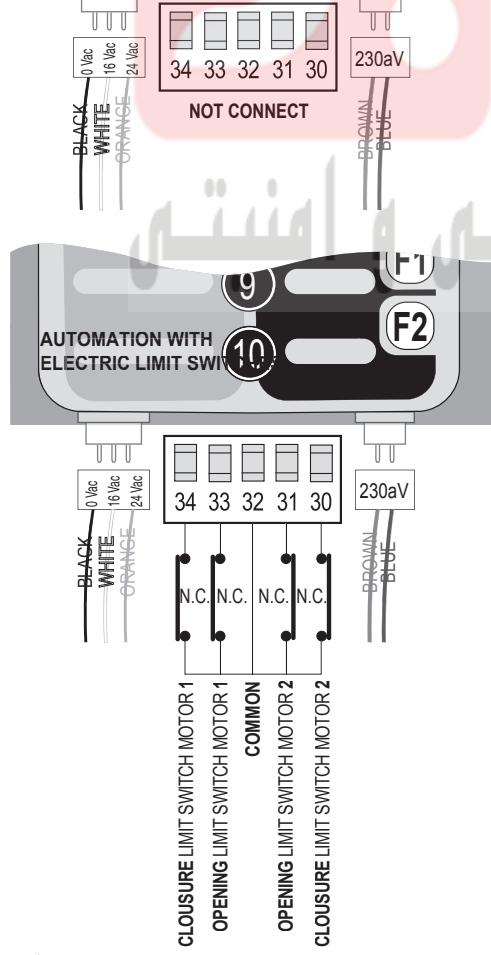
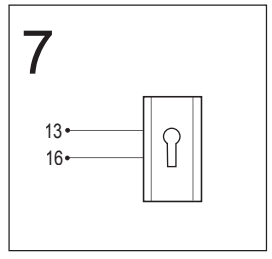
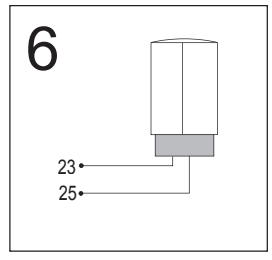
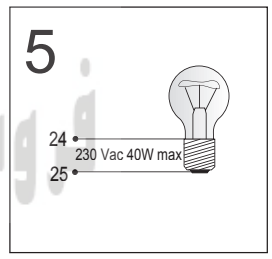
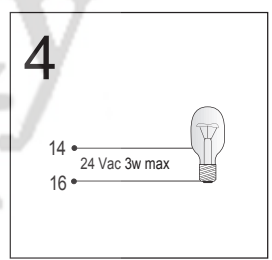
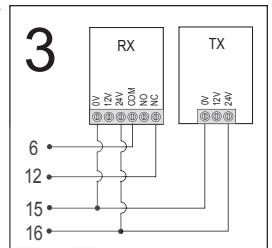
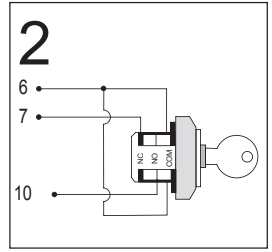
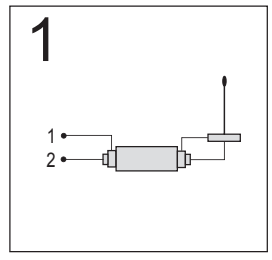

Istruzione di montaggio GEBOX.  
GEBOX assembly instructions  
Instructions de montage GEBOX  
Instrucciones de montaje GEBOX.

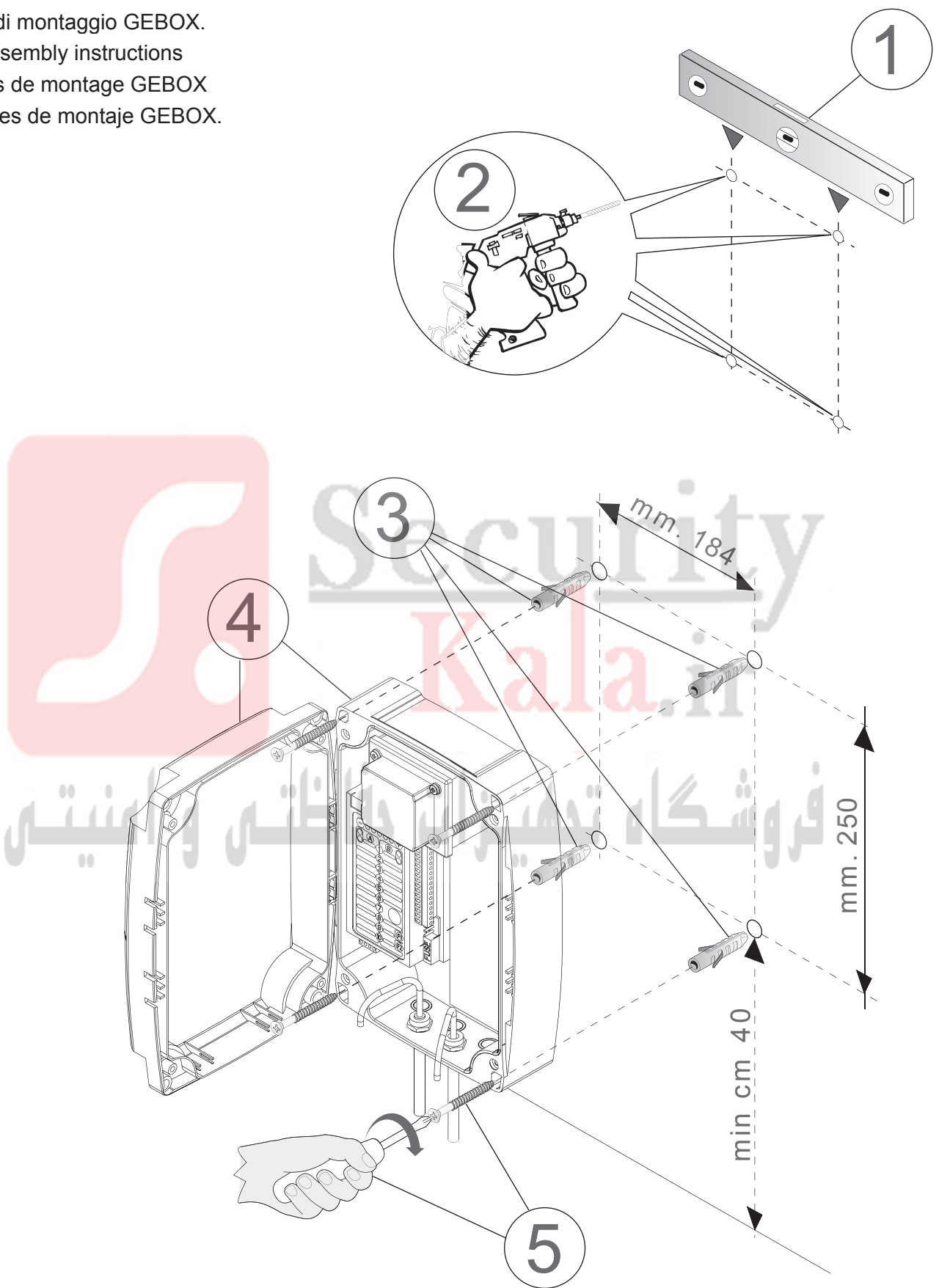

RICAMBI.  
SPARE PARTS  
RECHARGE  
RECAMBIOS

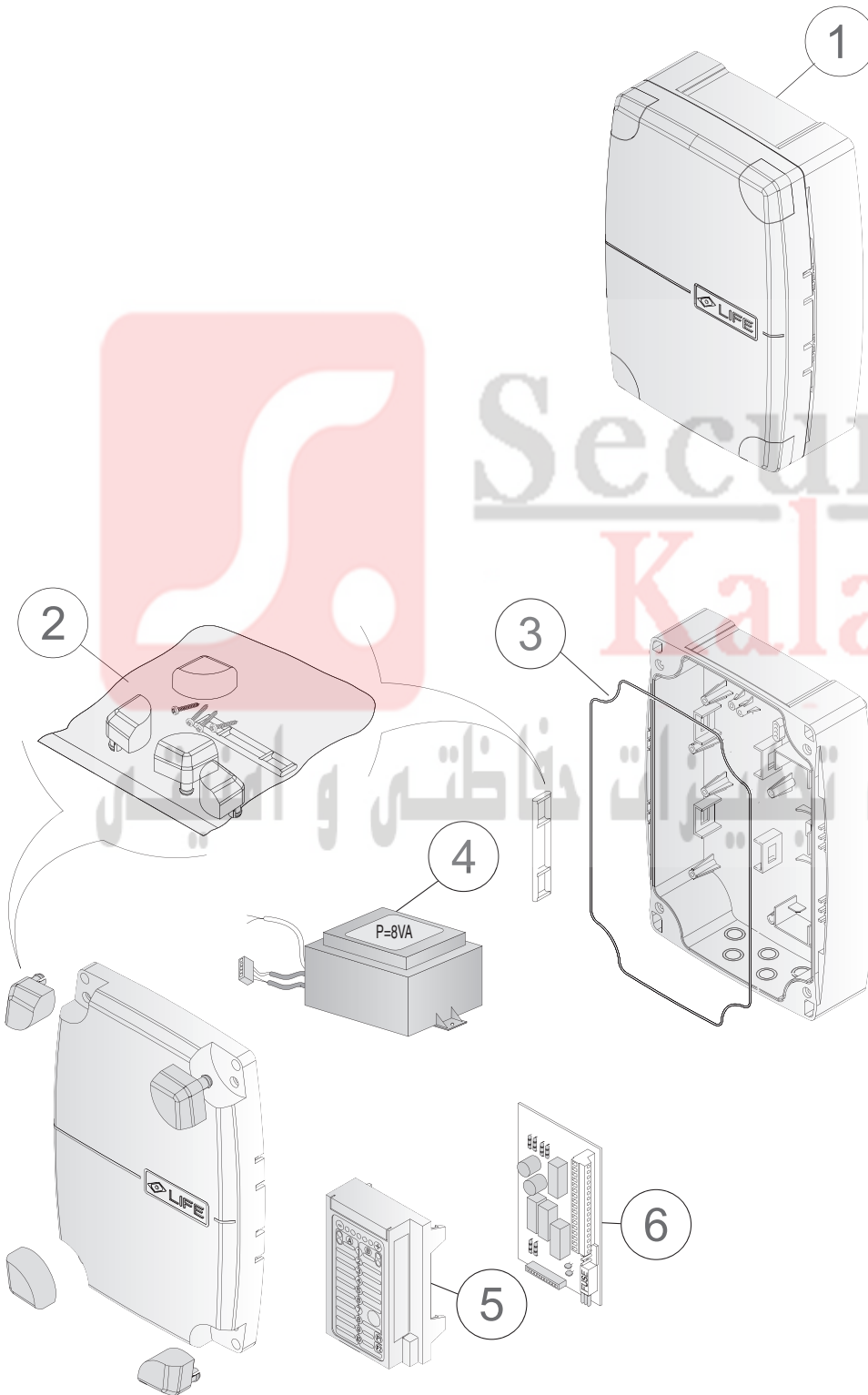
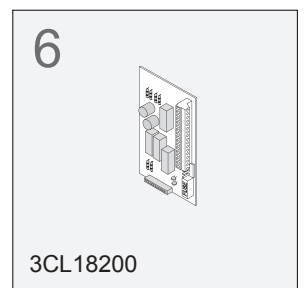
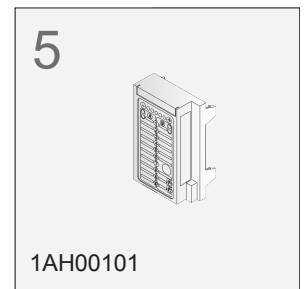
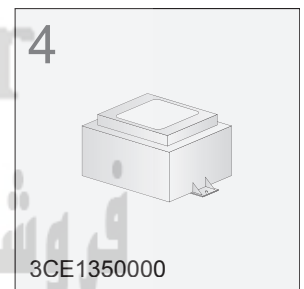
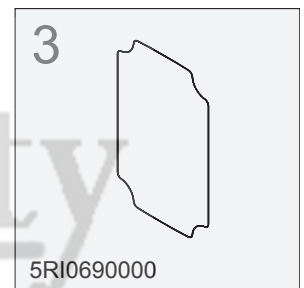
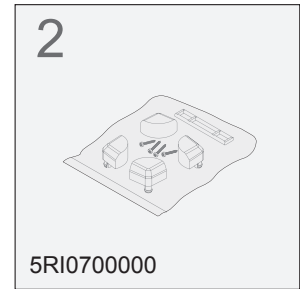



Security  
Kala.ir

فروشگاه تجهیزات حفاظتی و امنیتی



Address: **Via I Maggio, 37 - 31043 FONTANELLE (TV) Italia**  
Telephone: **+ 39 0422 809 254**  
Telefax: **+ 39 0422 809 250**  
http: **www.homelife.it**  
e-mail: **info@homelife.it**



## CONTROL UNIT FOR TWO-LEAF GATES GE UNI R

Instructions and warnings for installation, use and maintenance

**MANUAL DESTINED FOR USE BY PROFESSIONAL FITTERS ONLY**

Installation may only be performed by professional fitters

# INDEX

<b>INSTALLATION OF AUTOMATIONS WITH STOP PLATES. INSTALLATION OF AUTOMATIONS WITH ELECTRIC STOP SWITCHES.</b>	<b>2</b>	3.3.2	Pre-flashing.	21
<b>1 WIRING AND CONNECTIONS.</b>	<b>9</b>	3.3.3	Flashing in pause.	21
1.2. Preliminary checks.	9	3.3.4	Photo test.	21
1.3. GEBOX container installation.	9	3.3.5	Photo 1.	22
1.3.1. Control unit extraction.	9	3.3.6	Close after photo.	22
1.4. List of electric cables.	9	3.3.8	Force.	23
1.5. Setting up the electric system and connection to the mains supply.	9	3.3.9	Pause time.	23
1.6. Introducing the electric wires into the GEBOX.	9	3.3.10	Courtesy light.	23
1.7. Control unit connections.	10	3.3.11	Deceleration in opening and closure.	24
1.7.1. Wiring diagram of the right hand side of the control unit.	10	3.3.12	Obstacle detection.	24
1.7.2. Wiring diagram of the lower part of the control unit.	11	3.3.13	Pedestrian opening.	24
1.7.3. Indicator LEDs.	11	3.4	Fuses.	25
<b>2 STARTING UP.</b>	<b>12</b>	3.4.1	Frontal fuses.	25
2.1. Description of the keyboard.	12	3.4.2	Card fuses.	25
2.2. Radio control identification.	13	3.5	Preset functions F1 & F2.	25
2.2.1. STEP command identification.	13	<b>4 TROUBLESHOOTING.</b>	<b>26</b>	
2.2.2. PEDESTRIAN command identification.	13	4.1	Malfunctions indicated on the control unit.	26
2.2.3. Radio control resetting.	13	<b>5 AUTOMATION USE.</b>	<b>26</b>	
2.2.4. Resetting all identified radio controls.	14	5.1	Flashing light functions.	27
2.2.5. Identification without using the keyboard.	14	5.2	Automation malfunction.	26
2.3. Initialisation.	15	<b>6 general information.</b>	<b>26</b>	
2.3.1. Operators without electric stop switches: direction, travel and speed identification.	15	6.1	Information on the manufacturer.	26
2.3.2. Operators with electric stop switches: direction, travel and speed identification.	17	6.2	Intende use.	27
<b>3 ADJUSTMENTS.</b>	<b>18</b>	<b>7 SAFETY INSTRUCTIONS AND WARNINGS GENERAL.</b>	<b>27</b>	
3.1.1. Card initialisation.	18	7.1	General instructions and warnings.	27
3.1.2. Resetting travel and functions.	18	7.2	Storage instructions and warnings.	27
3.1.2. Resetting the travel.	19	<b>8 INSTALLATION.</b>	<b>27</b>	
3.2. Function modes.	19	8.1	Instructions and warnings for installation.	27
3.2.1. Dead man.	19	<b>9 TESTING AND TRIAL RUN.</b>	<b>28</b>	
3.2.2. Semi-automatic.	19	9.1	Testing.	28
3.2.3. 2-step automatic.	20	9.2	First Usage.	28
3.2.4. 4-step automatic.	20	<b>10 SAFETY INSTRUCTIONS AND WARNINGS FOR USE.</b>	<b>28</b>	
3.2.5. Condominium.	20	10.1	Indications and warnings for use.	28
3.3. Functions.	21	<b>11 MAINTENANCE.</b>	<b>29</b>	
3.3.1. Blackout.	21	11.1	Maintenance instructions and warnings.	29
		11.2	Routine maintenance.	29
		<b>12 DEMOLITION AND DISPOSAL.</b>	<b>29</b>	
		<b>13 MANUFACTURER'S DECLARATION OF CONFORMITY.</b>	<b>29</b>	



## INSTALLATION OF AUTOMATIONS WITH STOP PLATES

### PHASE 1

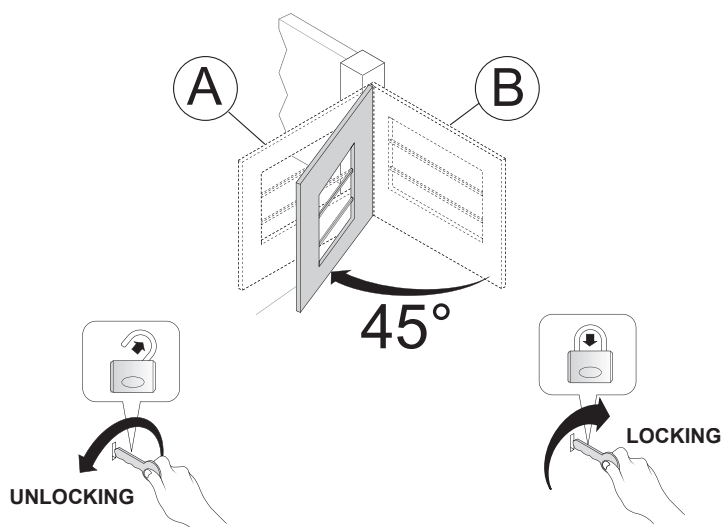

- Adjust the opening (A) and closure (B) stop switches or check the quality of the application's mechanical plates.
- Position the leaves at 45°.

### PHASE 2

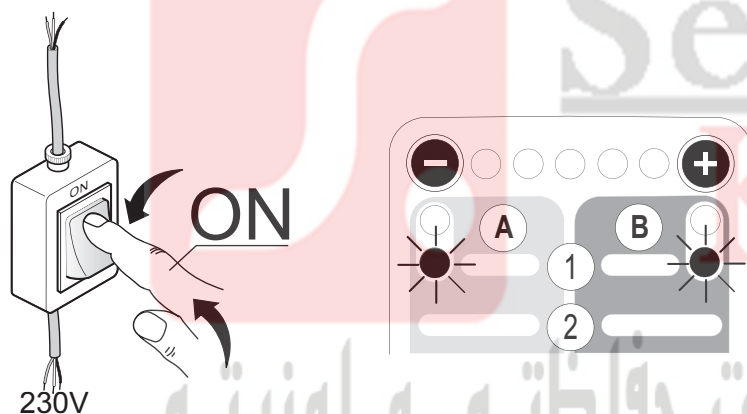

Switch on the system's power supply and check that the two red LEDs flash.

### PHASE 3

#### RADIO CONTROL IDENTIFICATION ON THE STEP COMMAND (A)

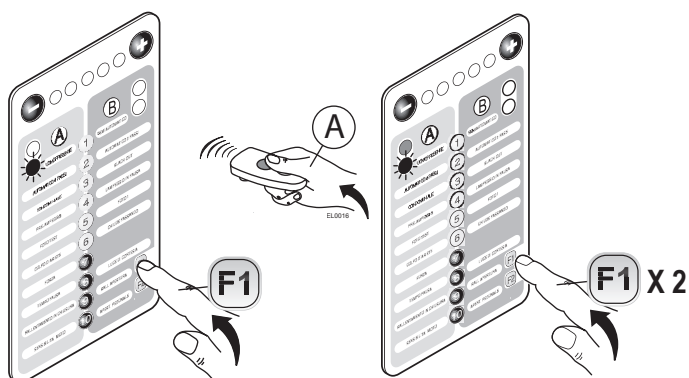

- Press **F1**, the red LED (**SX**) will start to flash.
- Hold down the radio control key until the green LED lights briefly. The green light indicates that the radio control has been identified.
- Wait for 15 secs or press **F1** twice to exit.

## PHASE 4

## CARD INITIALISATION

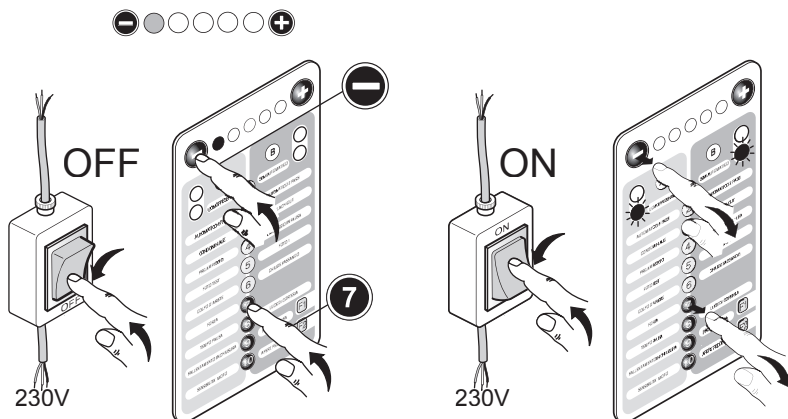

- Switch off power supply.
- Simultaneously press and hold down **-** and **9** and switch on the power supply to the system to light the third LED.
- Release keys **-** and **9**, the two red LEDs will now flash.

## PHASE 4.1

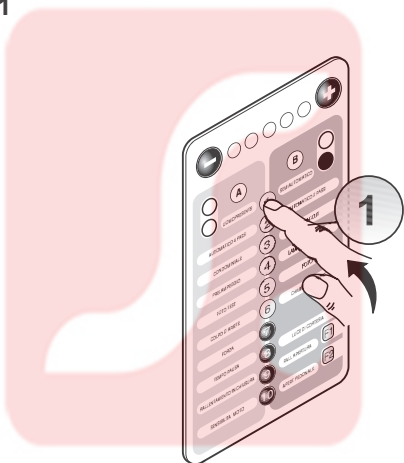

In the case of a **SINGLE** operator only press **1**: the red LED (**DX**) lights.

Being a single leaf system, staggering will not be indicated for the manoeuvres below.

## PHASE 5

## LEAF 2 LEAF 1 CLOSURE STOP PLATE IDENTIFICATION

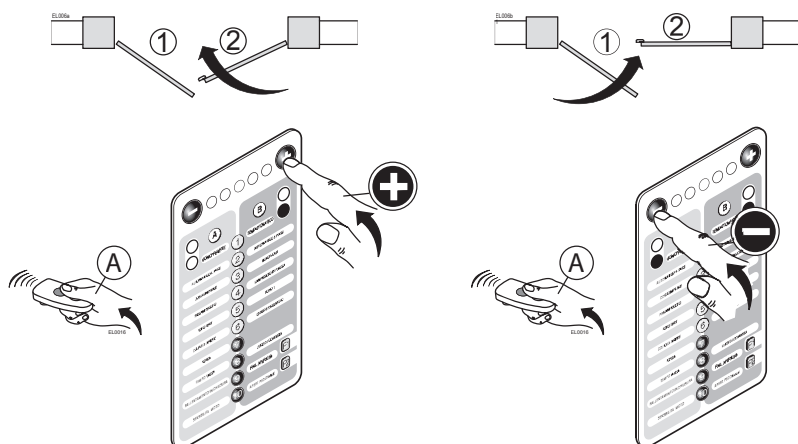

- Give the step command (**A**), holding it down until leaf (**2**) slowly reaches and pushes for a few seconds against the closure stop plate.  
Press **+** to identify the stop plate: the red led (**DX**) will light. When the leaf (**2**) has identified the closure stop plate the red LED (**DX**) only remains lit.
- Give the step command (**A**), holding it down until leaf (**1**) slowly reaches and pushes for a few seconds against the closure stop plate.  
Press **-** to identify the stop plate: the red led (**SX**) will light. When the leaf (**1**) has identified the closure stop plate the red LEDs (**SX**) and (**DX**) remain lit.

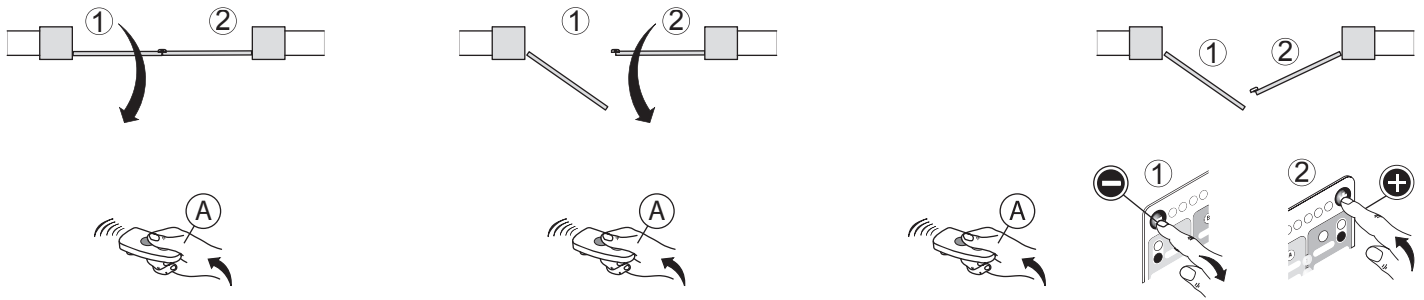
**PHASE 6.1****IDENTIFICATION OF STAGGERING AND OPENING STOP PLATE (a)**

- a) Give the step command **(A)** and release; the leaf **(1)** will open. When it reaches the point at which one also wishes to open leaf **(2)** (opening staggering) give the step command **(A)** and release: leaf **(2)** will open.
- b) When one of the two leaves reaches the opening desired position, give and release the step command **(A)**: both leaves will stop.  
Depending on whether it is leaf **(1)** or leaf **(2)**:
- Press **(-)** to define the **opening** stop plate of the leaf **(1)**: the red LED **(SX)** will light.
  - Press **(+)** to define the **opening** stop plate of the leaf **(2)**: the red LED **(DX)** will light.

**PHASE 6.2****IDENTIFICATION OF STAGGERING AND OPENING STOP PLATE (b)**

- a) Give and release the step command **(A)**, the leaf with the undefined stop plate starts to open slowly.
- b) When the moving leaf reaches the desired open position, give and release the step command **(A)** again: it will stop;  
Depending on whether it is leaf **(1)** or leaf **(2)**:
- Premere **(-)** to define the opening stop plate of the leaf **(1)**: the red LED **(SX)** will light.
  - Premere **(+)** to define the opening stop plate of the leaf **(2)**: the red LED **(DX)** will light.

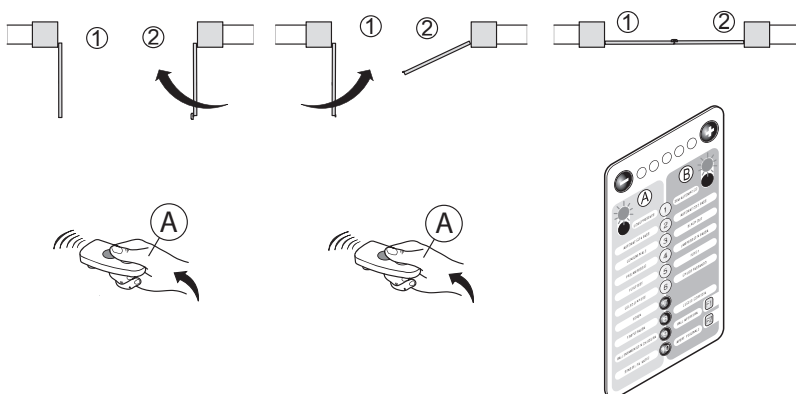
**PHASE 7****IDENTIFICATION OF CLOSURE STAGGERING AND STOP PLATE**

- a) Give and release the step command **(A)**: leaf **(2)** will close. When it reaches the point at which one also wishes to close leaf **(1)** (closure staggering) give and release the step command **(A)**: leaf **(2)** will close. The leaves now both move at a normal speed when closing.
- b) On reaching the closure position, the green LEDs flash and the red LEDs remain lit.

**The automation is now programmed.** The automation is now in **semi-automatic** mode by default. If you are dissatisfied with the result obtained, **reset the control unit** and repeat procedure from start.

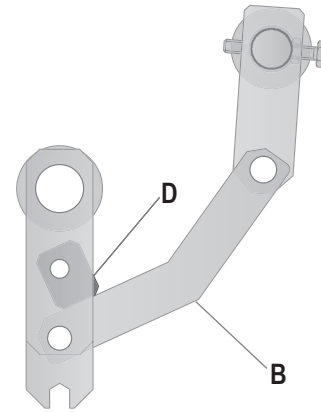
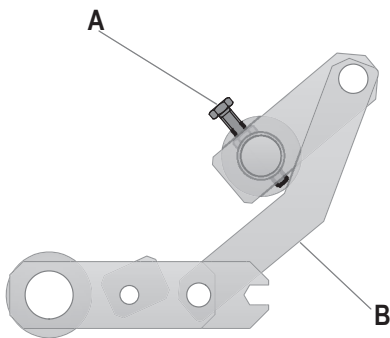
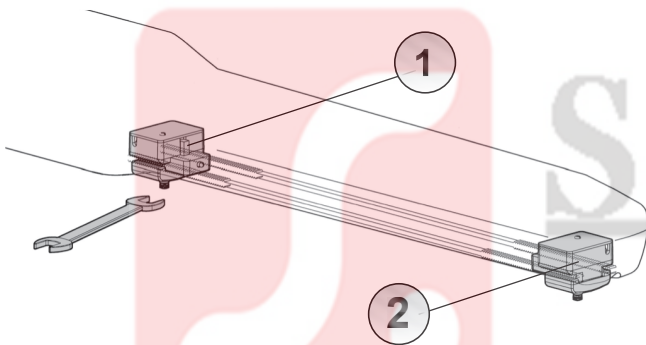
**ERGO: ADJUSTING THE OPENING AND CLOSURE MECHANICAL STOP PLATES****CLOSURE:** Adjust screw (A) abutting on the lever (B).**OPENING:** Adjust the retainer plate (D) abutting on the lever (B).**OPTIMO: ADJUSTING THE OPENING AND CLOSURE MECHANICAL STOP PLATES**

Adjust the position of the (1) CLOSURE and (2) OPENING mechanical plates.

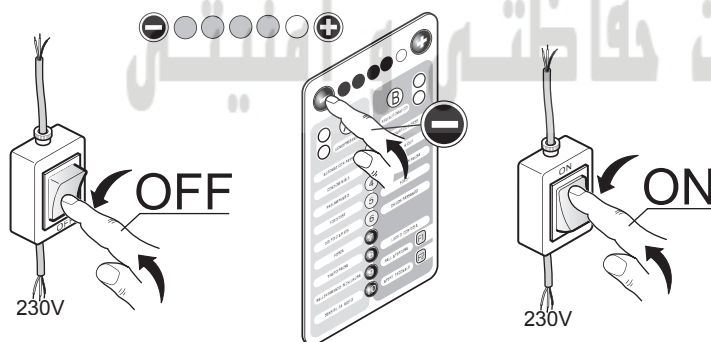
**RESETTING THE CONTROL UNIT**

a) Switch off the system's power supply.

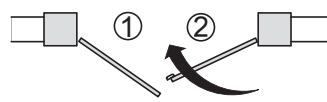
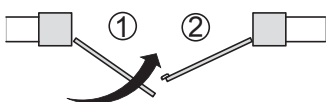
b) Press  and switch on the system's power supply until all four LEDs light.

a) While the operator (1) moves in opening or closing, the green LEDs and left red LED flash alternately.

b) While the operator (2) moves in opening or closing the green LEDs and right red LED flash alternately.

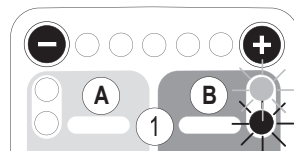

## INSTALLATION OF AUTOMATIONS WITH ELECTRIC STOP SWITCHES

### PHASE 1

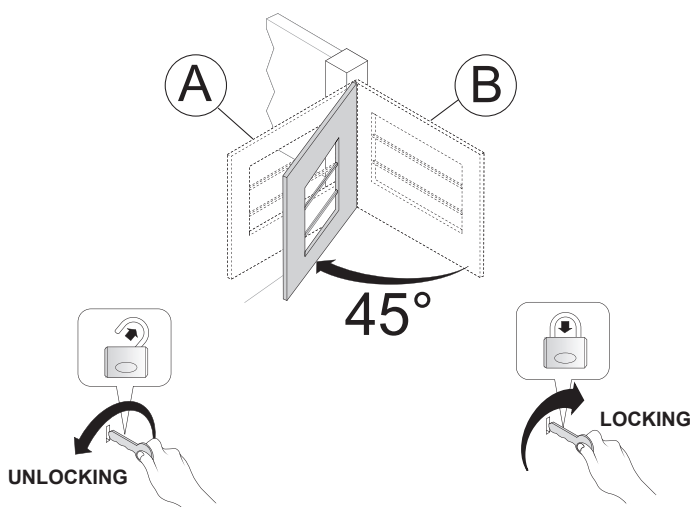

- Release the operator.
- Adjust the opening (A) and closure (B) stop plates.
- Position the leaves at 45°
- Relock the operator.

### PHASE 2

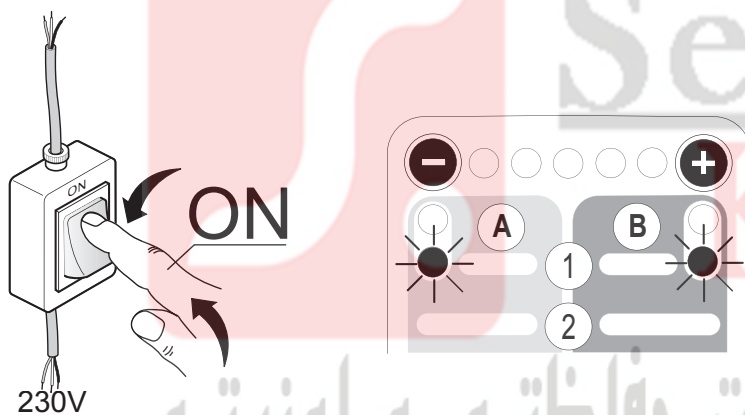

Switch on the system's power supply and check that the two red LEDs flash.

### PHASE 3

#### RADIO CONTROL IDENTIFICATION ON THE STEP COMMAND (A)

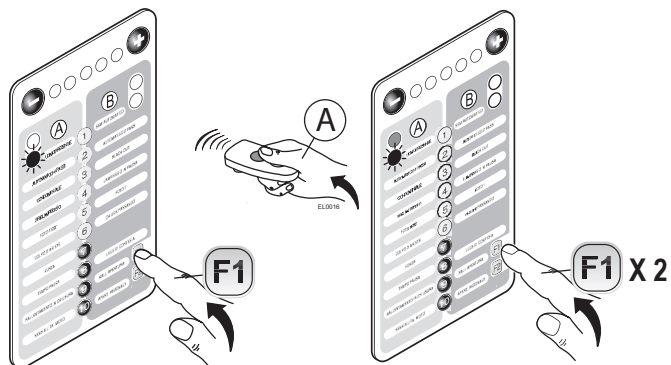

- Press **F1**, the red LED (**SX**) will start to flash.
- Hold down the radio control key until the green LED lights briefly. The green light indicates that the radio control has been identified.
- Wait for 15 secs or press **F1** twice to exit.

## PHASE 4

## CARD INITIALISATION

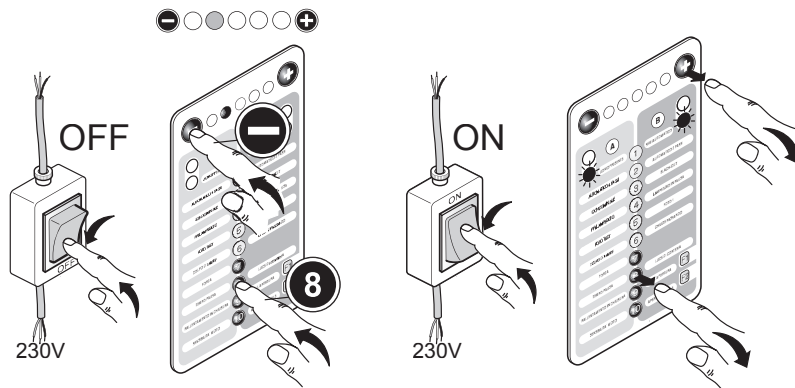

- Switch off power supply.
- Simultaneously press and hold down **-** and **8** and switch on the power supply to the system to light the second LED.
- Release keys **-** and **8**, the two red LEDs will now flash.

ENGLISH

## PHASE 4.1

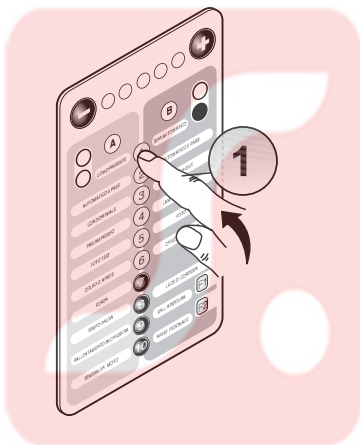

In the case of a **SINGLE** operator only press **1**: the red LED (**DX**) lights steadily.

Being a single leaf system, staggering will not be indicated for the manoeuvres below.

**ATTENTION:** if a single operator is used, connect the stop plates to the motor 1 terminals: 34-32 and 33-32; jumper the motor 2 stop plate inputs: terminals 31-32 and 30-32.

## PHASE 5

## LEAF 2 CLOSURE STOP PLATE IDENTIFICATION:

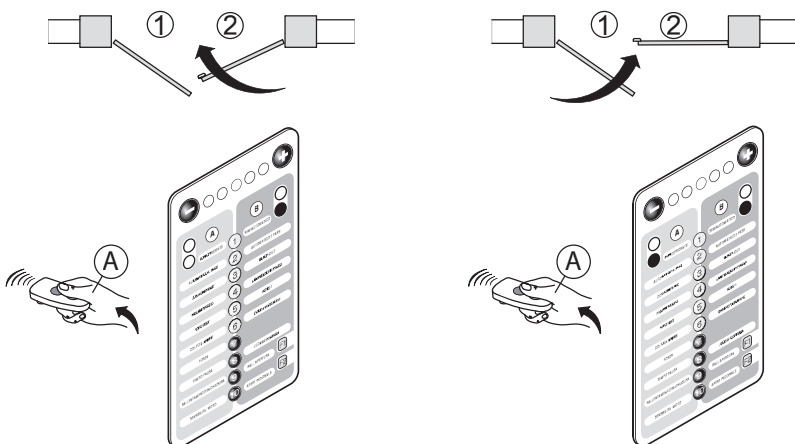

- Give the step command (**A**), holding it down until leaf (**2**) slowly reaches and pushes for a few seconds against the closure stop plate.  
Release the step command (**A**), when the micro is reached, the red LED (**DX**) will light.
- Give the step command (**A**), holding it down until leaf (**1**) slowly reaches and pushes for a few seconds against the closure stop plate.  
Release the step command (**A**), when the micro is reached, the red LED (**SX**) will light.



## PHASE 6

### IDENTIFICATION OF STAGGERING AND OPENING STOP PLATE

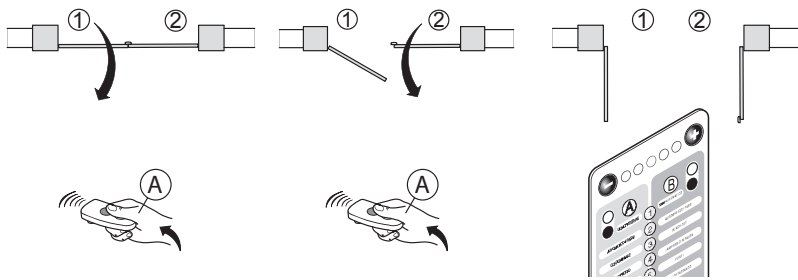

- Give the step command (A) and release; the leaf (1) will open. When it reaches the point at which one also wishes to open leaf (2) (opening staggering) give the step command (A) and release: leaf (2) will open. The two leaves continue to open slowly.
- When they have both reached the opening stop plate micros both red LEDs light.

## PHASE 7

### IDENTIFICATION OF CLOSURE STAGGERING AND STOP PLAT

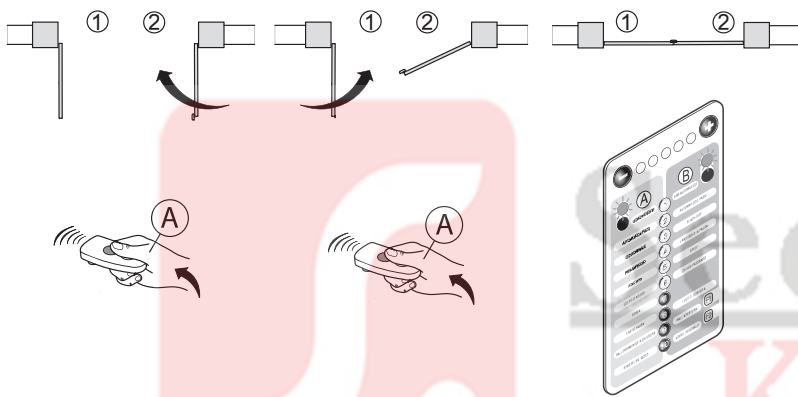

- Give and release the step command (A): leaf (2) will close. When it reaches the point at which one also wishes to close leaf (1) (closure staggering) give and release the step command (A): leaf (1) will close. The leaves now both move at a normal speed when closing.
- On reaching the closure stop plate micros, the green LEDs flash and the red LEDs remain lit.

The automation is now programmed. The automation is now in **semi-automatic** mode by default. If you are dissatisfied with the result obtained, **reset the control unit** and repeat procedure from start.

## RESETTING THE CONTROL UNIT

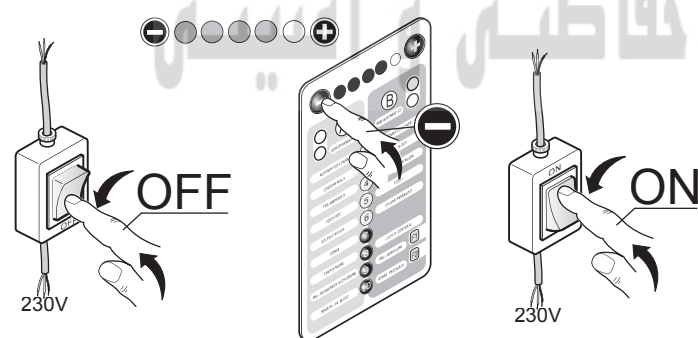

- Switch off the system's power supply.
- Press  and switch on the system's power supply until all four LEDs light.

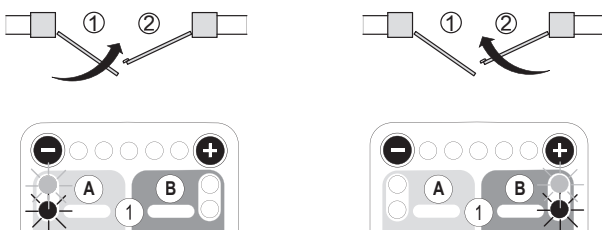

- While the operator (1) moves when opening or closing the green LEDs and left red LED flash alternately.
- While the operator (2) moves when opening or closing the green LEDs and right red LED flash alternately.

# 1 WIRING AND CONNECTIONS

- Before commencing wiring and connection work, read the **SAFETY INSTRUCTIONS AND WARNINGS** and **INSTALLATION INSTRUCTIONS AND WARNINGS** Chaps.
- All wiring and connection operations must be carried out with the control unit disconnected from the electricity supply (and from the buffer battery if present); if the disconnection device is not in view, display a sign reading "ATTENTION: MAINTENANCE WORK IN PROGRESS".

## 1.2 Preliminary checks

Before proceeding with installation, the following preliminary checks must be performed on the gate and installation area:

- 1) The area in which the control unit is installed must not be prone to flooding; it is therefore forbidden to install it excessively close to the ground. The optimal installation height is between 80 and 150 cm from the ground, the minimum 40cm.
- 2) The installation area should be as sheltered as possible from atmospheric agents and must allow the fitter good accessibility for installation and subsequent work.
- 3) The surfaces on which the GEBOX is mounted (column, pillar, wall, etc.) must be smooth and vertical, and adequately solid and compact to allow secure fastening.

## 1.3 GEBOX container installation

- a) Remove the cover and hinge from the GEBOX and decide on the mounting position, verifying that:
  - it is at least 40 cm from the ground;
  - the outlet of the pipe housing the electric cables is just below the container.
- b) Mark the centres of the four clamping screws and make holes for the screw anchors.
- c) Place the screw anchors inside the holes, rest the container against the wall and fasten securely using suitable screws.
- d) Carefully clean the inside of the container to remove any plaster dust or other residues.
- e) Fit the hinge into the dedicated recess on the left or right side of the container.
- f) Fit the cover onto the hinge then rotate to close it.
- g) Lock the lid by tightening the two screws in the holes in the corners on the opposite side to the hinge.
- h) Assemble the four screw cover inserts on the corners of the cover.

### 1.3.1 Control unit extraction

In order to facilitate control unit wiring or programming, it can be pulled out of its housing without requiring the use of tools.

- a) Push the control unit upwards to release the clips and pull outwards.
- b) Compatibly with the length of the cables, rest on the edge of the container or hold.

Once the wiring and/or programming work is complete, place the control unit back in its recess by pressing lightly until the 4 clips snap in.

## 1.4 List of electric cables

Depending on the installation, the type and quantity of devices installed, the cables required may vary. The table below shows the cables needed for a typical installation.

The cables used in the installation must be IEC 60335 compliant.

**ATTENTION: the cables used must be suited to the type of installation. It is the Fitter's responsibility to choose appropriate material.**

- All wires must be unsheathed as little as possible (6mm at the most) and as close as possible to the connection terminals, in order to prevent accidental contact with live parts in the event that cables disconnect from the terminals.
- Do not pre-seal cables to be fastened to the terminals using screws.
- If it is possible that wires subject to voltage higher than 50 Volt RMS and very low voltage safety wires may come into contact with one another, wires with voltage higher than 50 volt RMS must be insulated with a sheath; or the very low voltage safety wire must have an insulating sheath at least 1mm thick.
- All external connection cables must not be of the flat twin tinsel cord type.

Pos.	Connection	Type of cable
1	Electricity supply line	2x1.5 mm <sup>2</sup> cable
2	Flashing light	2x1 mm <sup>2</sup> cable
3	Radio aerial	Screened RG 58 50 Ω cable
4	Tx Photo	2x1 mm <sup>2</sup> cable
5	Rx Photo	4x1 mm <sup>2</sup> cable
6	Selector	3x1 mm <sup>2</sup> cable
7	Encoder	2x1 mm <sup>2</sup> cable
8	Electricity supply line	2x1.5 mm <sup>2</sup> cable

## 1.5 Setting up the electric system and connection to the mains supply

This manual does not describe how the electric system should be prepared for connection to the mains. It does, however, give the following warnings:

- **The electricity supply line must be installed and connected by an authorised electrician or professional fitter.**
- **The electricity supply must be adequately protected against short circuits and static discharge.**
- **The power supply network must contain an omnipolar disconnection device with an opening distance of the contacts equal or greater than 3.5 mm that assures the complete disconnection of the power supply.**

## 1.6 Introducing the electric wires into the GEBOX

- a) Open the required pre-punched holes in the bottom of the container (remembering that it is compulsory to keep 230V wires separate from those with very low voltages).
- b) Position cable glands suited to maintaining the degree of protection of the container inside the holes.
- c) Pass the wires needed for the connections through the cable glands, leaving an additional length of approximately 40 cm
- d) Carefully close the cable glands and seal the ends of the tubes with silicon in order to prevent access to insects and/or dirt.



## 1.7 Control unit connections

Fitters must make the connections of the 230 Vac 50 Hz electricity supply, the motors and the various automation devices. Connections between the control unit and the transformer have already been performed by the Manufacturer.

- Once the connections to the control unit have been made, the Fitter must use bands to join adjacent wires into groups of 2, 3 or 4 in order to prevent them coming away from the terminal board: bands must be attached as close as possible to the terminals, no more than 10mm away, taking care not to damage wire insulation. No cable may remain unpaired.
- The bands are only for unsheathed cables (sheathed cables are held in place by the sheath).
- Pay careful attention not to pair wires with voltages higher than 50 Volt RMD with lower voltage wires.
- The wiring performed internally by the manufacturer is already equipped with clamping bands.

### 1.7.1 Wiring diagram of the right hand side of the control unit

The table below shows a diagram of the connection terminals for the aerial, various controls and the power supplies for the various devices (indicator light, electrolock, flashing light, courtesy light, photocells, selectors, etc.). These are the vertical terminals positioned on the right hand side of the control unit and numbered from 1 to L1.

Terminals	Description (SEE WIRING DIAGRAM on page 2A)	
1	AERIAL: aerial sheath input	Use a RG58- 50ohm cable
2	AERIAL: aerial cable input	
6	COMMAND AND PHOTOCELL COMMON: for stop, open, close, step and photo inputs.	
6 - 7	STOP*: programmable NC input, commands gate stoppage. Can be connected to safety devices such as an emergency stop button. When the command is released automatic closure never occurs and a new movement command must be given. <b>Leave jumpered if no device is envisaged.</b>	
6 - 8	OPEN: NO input, commands gate opening.	
6 - 9	CLOSE: NO input, commands gate closure.	
6 - 10	STEP: NO input, commands gate movement according to the following cycles: SEMI-AUTOMATIC MODE: Open, stop, close, stop. 4-STEP MODE Open, pause, close, pause. 2-STEP MODE Open – close. CONDOMINIUM MODE: Open.	
6 - 11	FOTO1*: programmable NC input for photocells or safety devices. Causes gate stoppage during both opening and closure. Motion resumes during opening when the photocell or safety device is disengaged. Leave jumpered if no device is envisaged.	
6 - 12	PHOTO: NC input for photocells or safety devices. Does not intervene during gate opening; during closure causes reversal of gate motion until open. <b>Leave jumpered if no device is envisaged.</b>	
16 - 13	ELECTROLOCK 24 V ac output for connection of the 24 Vac 15 VA electrolock.	
16 - 14	INDICATOR LIGHT: 24Vac 3W max output, for connecting an indicator light that copies the function of the flashing light during movement and that remains on when the gate is open.	
16 - 15	24 V ac OUTPUT: power supply for various devices, 200 mA max.	
16	ELECTROLOCK, INDICATOR LIGHT AND 24 V ac OUTPUT COMMON.	
17	PHASE 1, CAPACITOR	OPERATOR 2 POWER SUPPLY: 230 Vac 50 Hz output 300 W max.
18	COMMON	
19	PHASE 2, CAPACITOR	
20	FASE 1, CONDENSATORE	OPERATOR 1 POWER SUPPLY: 230 Vac 50 Hz output 300 W max.
21	COMMON	
22	FASE 2, CONDENSATORE	
23 - 25	FLASHING LIGHT: 230 Vdc 25W max output for connecting a SPLENDOR SRL flashing light characterised by three flashing modes: 1) slow during door opening; 2) fast (flashing times halved) during closure. 3) three flashes and a pause to indicate a fault state or travel identification.	
24 - 25	COURTESY LIGHT: 230 Vdc 40W max. output for connecting a courtesy light that switches on at the start of each movement (opening or closure) and is characterised by an adjustable on time.	
25	FLASHING OR COURTESY LIGHT POWER SUPPLY COMMON.	
L 2	230Vac 50Hz POWER SUPPLY, fusable input L2.	
L 1		



**N.C. = normally closed contact – NO = normally open contact**

\* 6-7 and 6-11 are NC inputs that can be set as **photo, photo1, photo2, stop, pause**.

**Photo 2:** NC input for photocells or safety devices. Does not intervene during gate closure; during gate opening it causes a brief reversal of motion, followed by stoppage until a new command is given.

**Stop:** commands gate stoppage. When the command is released, automatic closure never occurs and a new movement command must be given.

**Pause:** Causes a pause in the door's motion. If automatic closure at the end of the pause time is active, it causes re-closure, otherwise it waits for a new command.

**Pedestrian:** the command causes partial and adjustable opening of a single leaf. Can be given using a remote control or the terminal board. Obtained from the terminal board by jumpering terminal 8 OPEN with terminal 9 CLOSE, this jumper then connects with a switch to terminal 6 COMMON. When given from the terminal board, the PEDESTRIAN command excludes the OPEN and CLOSE commands.

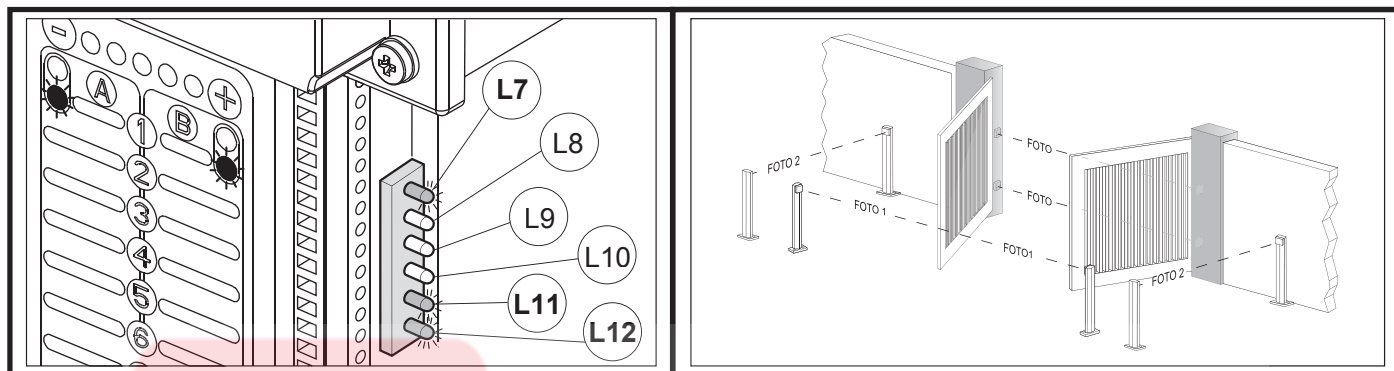

N.C. jumpered input

Layout typical installation photocells

**ATTENTION: the definition of leaf 1 and leaf 2 is essential for automation operation. Fitters must pay careful attention to the following.**

- Leaf 1:** is the first to open when the gate is closed and the second to move when the gate is open; it finishes its closure travel after leaf 2.
- Leaf 2:** is the second to open when the gate is closed and the first to move when the gate is open; it finishes its closure travel before leaf 1.

### 1.7.2 Wiring diagram of the lower part of the control unit.

The table below represents the terminals on the lower part of the control unit reserved for the connections for the board's electricity supply through the transformer, to the encoder connections and the transformer power supply.

Terminals	Description (See Wiring Diagram On Page 2a)					
37	0	BLACK CABLE	COMMON ELECTRONIC AND AUXILIARY POWER SUPPLY			
36	16	WHITE CABLE	FROSHGAH BEHIRAN KHAFESH			
35	24	ORANGE CABLE				
37 - 36	16v AC 0.5a ELECTRONICS POWER SUPPLY					
37 - 35	24Vac AUXILIARY POWER SUPPLY					
34 - 32	N.C.	CLOSURE	STOP PLATE MOTOR 1	IF A SINGLE OPERATOR IS USED, CONNECT THE STOP PLATES TO THE MOTOR 1 TERMINALS: 34-32 AND 33-32; JUMPER THE MOTOR 2 STOP PLATE INPUTS: TERMINALS 31-32 AND 30-32.	MOTOR 1 & 2 STOP PLATES	
33 - 32	N.C.	OPENING				
31 - 32	N.C.	CLOSURE				STOP PLATE MOTOR 2
30 - 32	N.C.	OPENING				
30	COM.	COMUNE DEI FINECORSA				
27	BROWN CABLE		TRANSFORMER POWER SUPPLY			
26	BLUE CABLE					

### 1.7.3 Indicator LEDs

There is a row of 6 LEDs on the right hand side of the board, under the terminals. These LEDs are lit when the corresponding signal is present. For the NC inputs, stop, photo 1 and photo, the corresponding LEDs L7, L11 and L12 are normally lit; for the NO inputs open, close and step, the corresponding LEDs L8, L9 and L10 are normally off. These LEDs therefore indicate any malfunction of the connected devices.



## 2 STARTING UP

### 2.1 Description of the keyboard

The keyboard on the control unit makes it possible to set all the functions necessary for a safe and controlled functioning of the automation.

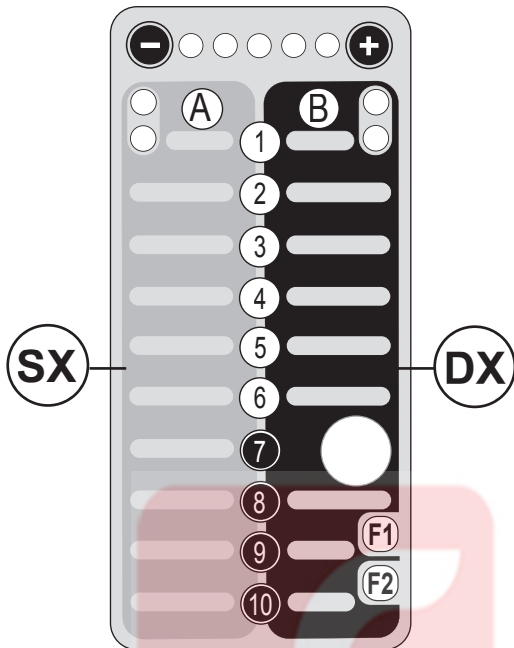

- It is constituted by a membrane keyboard divided by a central column of keys, (from ① to ⑩) into two vertical areas: the right-hand keyboard (black/blue) and the left-hand keyboard (grey/yellow). Each vertical keyboard manages and memorises certain operation parameters.
- The selection of the right or left keyboard takes place by pressing one of the two buttons with the symbol (A) or (B): the button (A) activates the TERMINAL STRIP (SX), and button (B); selects the TERMINAL STRIP (DX).
- Keyboard de-selection takes place automatically after a certain interval of time from the last key pressed with the exception of the FORCE ⑦ function, which remains active until another function is selected.

- When the LEDs (DX) and (SX) flash alternately, it is possible to set parameters ① to ⑩.



- The buttons  $\ominus$  and  $\oplus$  are used to vary the values or parameters.
- The horizontal row of red LEDs  $\ominus \bullet \bullet \bullet \bullet \oplus$ ; from 1 to 5 indicates the value set for a given parameter: the more LEDs lit, the higher the parameter value. They are also used as a status indicator for certain parameters.
- The lateral red LEDs indicate a non-set parameter status if they flash:  $\odot$ , and they indicate the detection of the stop plate signal (right or left) when they are lit:  $\bullet$ .
- The lateral green LEDs indicate a parameters set or correct function status according to the keyboard selected.

## 2.2 Radio control identification

The control unit is fitted with a built-in radio receiver with a 1000 code memory and 2 channels with a 433.92 MHz frequency with LIFE Rolling Code and Auto code encoding.

### 2.2.1 STEP command identification

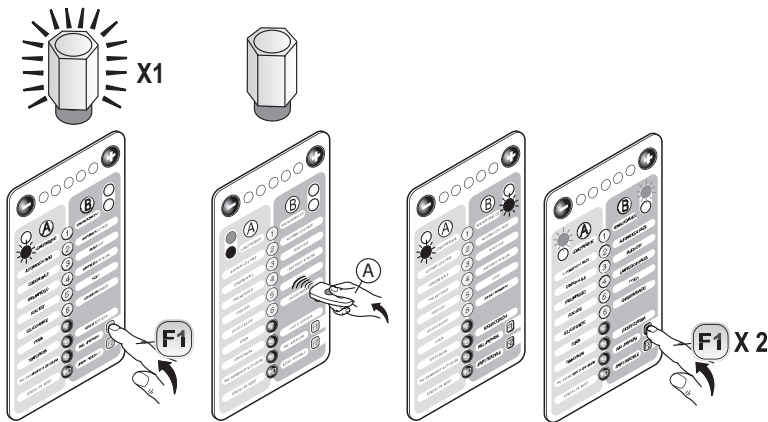

- 1) Press **F1** the red LED (**SX**) will flash slowly and the **SPLENDOR** flashing light (if present) will emit single flashes.
- 2) Press the key (**A**) on the radio control(s) that one wants to identify and hold down until the green LED (**SX**) and the **SPLENDOR**.
- 3) To exit identification, wait approximately 15 seconds until the two red LEDs flash if the travel has not yet been identified, or the two green LEDs when the travel has already been identified.
- 4) It is possible to exit without waiting the automatic exit time by pressing **F1** twice.

### 2.2.2 PEDESTRIAN command identification

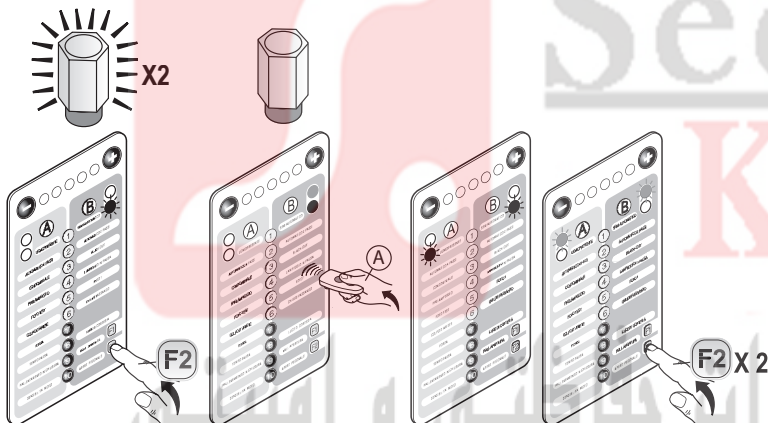

- 1) Press **F2** the red LED (**DX**) will flash slowly and the **SPLENDOR** flashing light (if present) will emit double flashes.
- 2) Press the key (**A**) of the radio control(s) that one wants to identify and hold down until the green LED (**DX**) and the **SPLENDOR** flashing light light briefly.
- 3) To exit identification, wait approximately 15 seconds until the two red LEDs flash if the travel has not yet been identified, or the two green LEDs when the travel has already been identified.
- 4) It is possible to exit without waiting the automatic exit time by pressing **F2** twice.

### 2.2.3 Radio control resetting

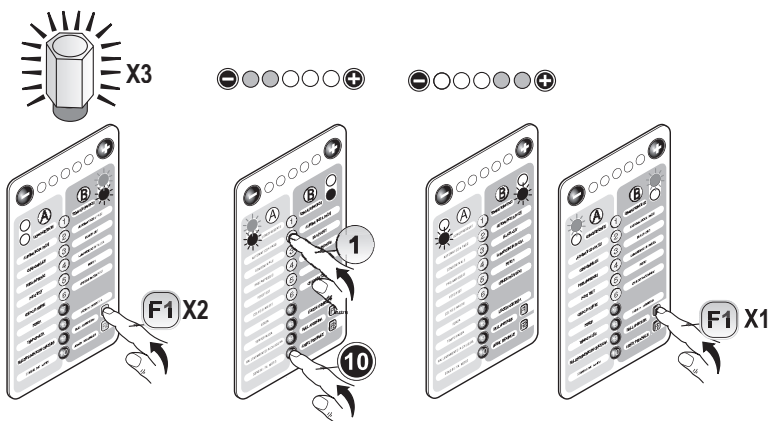

- 1) Press **F1**: twice: the two right LEDs and the two left LEDs will flash alternately while the flashing light emits a triple flash.
- 2) Press the key (**A**) on the radio control(s) that one wishes to reset.
- 3) To exit identification, wait approximately 15 seconds until the two red LEDs flash if the travel has not yet been identified, or the two green LEDs when the travel has already been identified.
- 4) It is possible to exit without waiting the automatic exit time by pressing **F1** once.



## 2.2.4 Resetting all identified radio controls

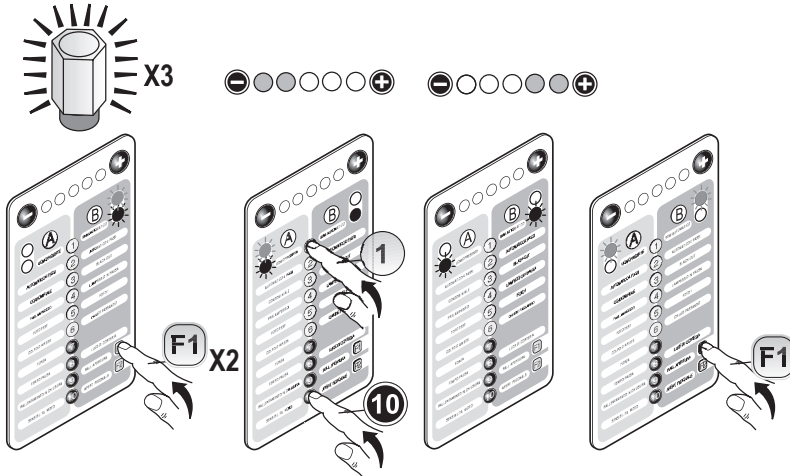

- 1) Press **F1** on the control unit twice, the two right LEDs and the two left LEDs will flash alternately whilst the **SPLENDOR** flashing light emits a triple flash.
- 2) Simultaneously press **1** and **10**, check the alternate flashing of the red LEDs  $\ominus \bullet \bullet \bullet \bullet \oplus$  and  $\ominus \bullet \bullet \bullet \bullet \oplus$ .
- 3) Wait until the LEDs switch off.
- 4) To exit identification, wait approximately 15 seconds until the two red LEDs flash if the travel has not yet been identified, or the two green LEDs when the travel has already been identified. It is possible to exit without waiting the automatic exit time by pressing **F1** once.

## 2.2.5 Identification without using the keyboard

### Definition of a master radio control

It is possible to create one or more master radio controls able to make the memory of the radio receiver accessible without using the keyboard.

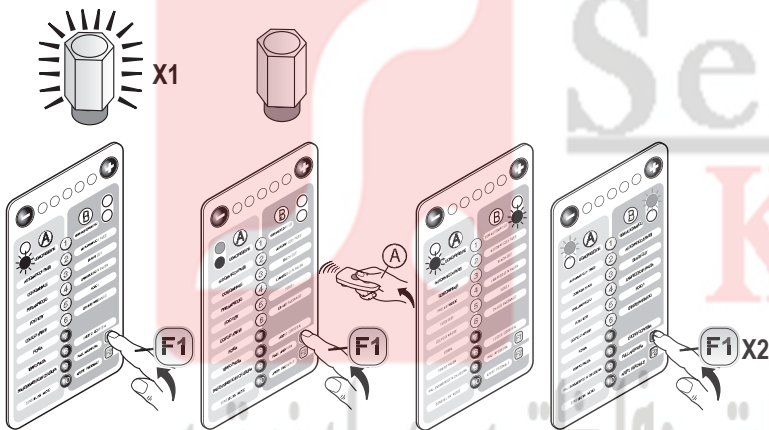

### Creation of the master

- 1) Identify the step and the pedestrian command on the radio control **(A)**, on two different keys, as described in the previous chap.
- 2) Press **F1** on the control unit and check that the red LED **(SX)** flashes slowly and the **SPLENDOR** light (if present) emits single flashes.
- 3) Simultaneously press the two keys **(A)** identified previously and hold down until the green LED **(SX)** and the **SPLENDOR** flashing light light briefly.
- 4) To exit identification, wait approximately 15 seconds until the two red LEDs flash if the travel has not yet been identified, or the two green LEDs when the travel has already been identified. It is possible to exit without waiting the automatic exit time by pressing **F1** twice.

### Using the master

To access the radio receiver memory simultaneously press the two keys **(1)** and **(2)** identified on the master remote control and press repeatedly to switch from one function to the next in the following order:

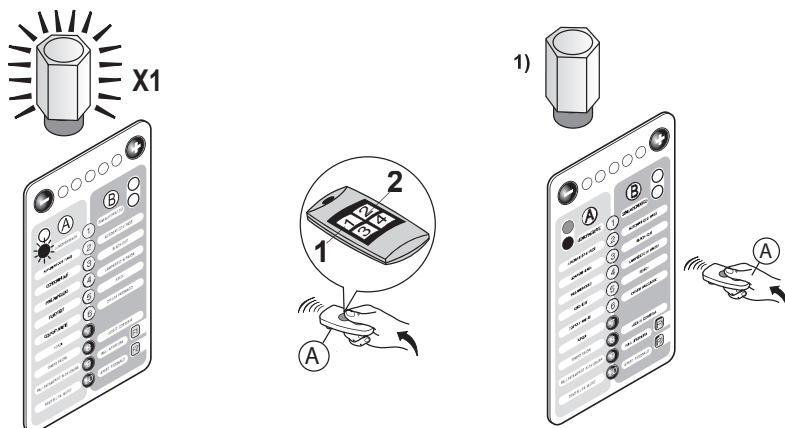

- 1) Step command identification: red LED will flash slowly and the flashing light will emit single flashes. Press the key **(A)** on the radio control(s) (not master) that one wants to identify and hold down until the green LED **(SX)** and the **SPLENDOR** flashing light light for a brief moment.

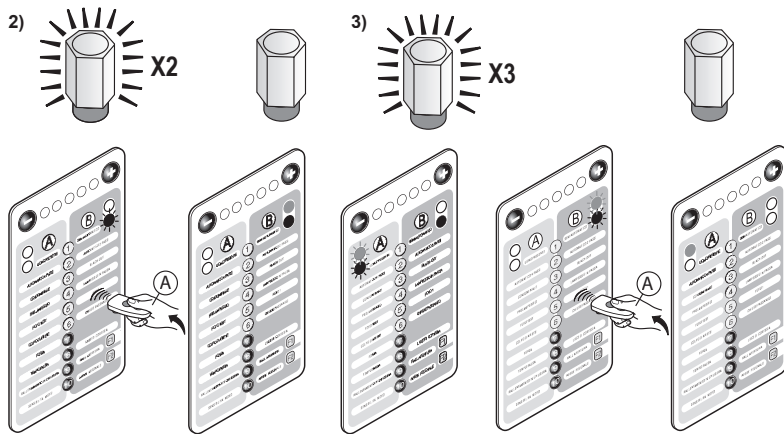

- 2) **Pedestrian command identification** the red LED (DX) will flash slowly and the flashing light will emit double flashes. Press the key (A) on the radio control(s) (not master) that one wants to identify and hold down until the green LED (DX) and the SPLENDOR flashing light light briefly.
- 3) **Radio control resetting:** the red and green LEDs (DX) and (SX) will flash alternately and the flashing light will emit a triple flash. Press the key (A) on the radio control(s) (not master) that one wants to reset and hold down until the green LED and the SPLENDOR flashing light light briefly.
- 4) **Exit programming.**

## 2.3 INITIALISATION

All the operations performed by the operator and gate during travel recognition are the Fitter's responsibility.

**ATTENTION: LIFE cards are multipurpose and may be used for several applications; therefore, on activation they require the identification of the type of automation that they will serve.**

- a) The control unit must **NOT** be powered electrically.
- b) Adjust the opening (A) and closure (B) stop plates or check the stop plates, position the leaf approximately 45° from the closure position.
- c) Follow the indications in the table below for the various types of operator:

APPLICATION	KEYS	HORIZONTAL LEDS
WITHOUT ELECTRIC STOP SWITCHES	⊖ + 9	⊖ ○ ○ ○ ○ ⊕
WITH ELECTRIC STOP SWITCHES	⊖ + 8	⊖ ○ ○ ○ ○ ⊕

For example: For the **OP3 UNI** operator, press ⊖ and 9, together, and holding them down, switch on the power supply to the control unit. Release the keys when the third red LED lights: ⊖ ○ ○ ○ ○ ⊕.

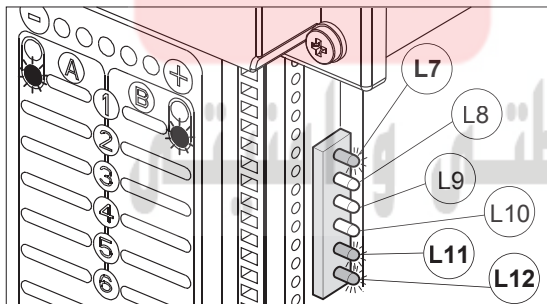

- d) Check that the 2 red LEDs flash.
- e) Check that the lateral LEDs, L7, L11 and L12 are switched on.
- f) Check that the lateral LEDs L8, L9 and L10 are switched off.
- g) In the case of a **SINGLE** operator only press 1: the red LED (DX) lights steadily.

**Being a single leaf system, staggering will not be indicated for the manoeuvres below.**

**ATTENTION: if a single motor application with electric stop plates is used, connect the stop plates to the motor 1 terminals: 34-32 and 33-32; jumper the motor 2 stop plate inputs: terminals 31-32 and 30-32.**

If this does not occur, check the connections and effectiveness of the various devices, assure that the NC inputs for which no device is connected are jumpered.

### 2.3.1 Operators without electric stop switches: direction, travel and speed identification

The direction and travel identification phases are performed at reduced speed.

#### PHASE 1

#### LEAF 2 CLOSURE STOP PLATE IDENTIFICATION:

Give the step command (A), holding it down until leaf (2) slowly reaches and pushes for a few seconds against the closure stop plate. Press ⊕ to identify the stop plate: the red led (DX) will light. When the leaf (2) has identified the closure stop plate the red LED (DX) only remains lit.

**ATTENTION**

If the gate does not move or struggles to move, it is necessary to raise the force value when the gate is immobile:

- 1) Press **(A)** followed by **FORCE (7)**.
- 2) Press **(+)** to increase the basic force values: the **(●●●●●●●)** LEDs will light.
- 3) Press **(B)** to exit.

**PHASE 2****LEAF 1 CLOSURE STOP PLATE IDENTIFICATION:**

Give the step command **(A)**, holding it down until leaf **(1)** slowly reaches and pushes for a few seconds against the closure stop plate. Press **(-)** to identify the stop plate: the red led **(SX)** will light. When the leaf **(1)** has identified the closure stop plate the red LED **(SX)** only remains lit.

**PHASE 3****IDENTIFICATION OF STAGGERING AND OPENING STOP PLATE**

- a) Give the step command **(A)** and release, the leaf **(1)** will open. When it reaches the point at which one also wishes to open leaf **(2)** (opening staggering) give the step command **(A)** and release: leaf **(2)** will open.
- b) When one of the two leafs reaches the desired open position, give and release the step command **(A)**: both wings stop, depending on whether they are leaf **(1)** or leaf **(2)**:
  - Press **(-)** to define the opening stop plate of the leaf **(1)**: the red LED **(SX)** will light.
  - Press **(+)** to define the opening stop plate of the leaf **(2)**: the red LED **(DX)** will light.
- c) Give and release the step command **(A)**, the leaf with the undefined stop plate starts to open slowly.
- d) When one of the two leafs reaches the desired open position, give and release the step command **(A)** again: it stops, depending on whether they are leaf **(1)** or leaf **(2)**:
  - Press **(-)** to define the opening stop plate of the leaf **(1)**: the red LED **(SX)** will light.
  - Press **(+)** to define the opening stop plate of the leaf **(2)**: the red LED **(DX)** will light.

**PHASE 4****IDENTIFICATION OF CLOSURE STAGGERING AND STOP PLATE**

- a) Give and release the step command **(A)**: leaf **(2)** will close. When it reaches the point at which one also wishes to close leaf **(1)** (closure staggering) give and release the step command **(A)**: leaf **(1)** will close. The leaves now both move at a normal speed when closing.
- b) On reaching the closure position, the green LEDs flash and the red LEDs remain lit.

**The automation is now programmed.** The automation is now in **semi-automatic** mode by default. If you are dissatisfied with the result obtained, **reset the control unit** and repeat procedure from start.

**RESETTING THE CONTROL UNIT**

- a) Switch off the system's power supply.
- b) Press **(-)** and switch on the system's power supply until all four LEDs light.

**ERGO: ADJUSTING THE OPENING AND CLOSURE MECHANICAL STOP PLATES**

**CLOSURE:** Adjust screw **(A)** abutting on the lever **(B)**.

**OPENING:** Position the retainer plate **(D)** on the threaded retainer or the 90° or maximum opening position (it is always advisable to install abutment stops on the leaf).

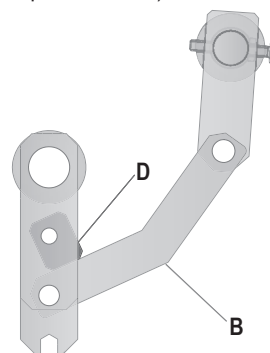
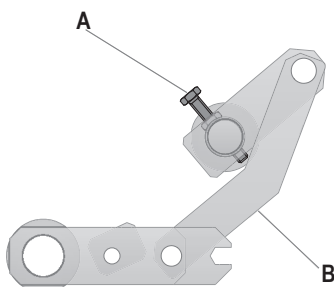

## OPTIMO: ADJUSTING THE OPENING AND CLOSURE MECHANICAL STOP PLATES

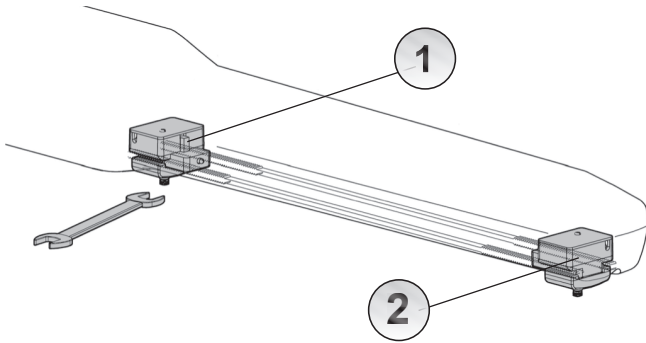

Adjust the position of the (1) CLOSURE and (2) OPENING mechanical plates.

### 2.3.2 Operators with electric stop switches: direction, travel and speed identification

The direction and travel identification phases are performed at reduced speed.

#### PHASE 1

LEAF 2 CLOSURE STOP SWITCH IDENTIFICATION:

- Give the step command (A), holding it down until leaf (2) slowly reaches and pushes for a few seconds against the closure stop plate. Release the step command (A), when the micro is reached, the red LED (DX) will light.
- Give the step command (A), holding it down until leaf (1) slowly reaches and pushes for a few seconds against the closure stop plate. Release the step command (A), when the micro is reached, the red LED (SX) will light.

#### ATTENTION

If the gate does not move or struggles to move, it is necessary to raise the force value when the gate is immobile:

- Press (A) followed by FORCE (7).
- Press (+) to increase the basic force values: the ●●●●●○(+) LEDs will light.
- Press (B) to exit.

#### PHASE 2

IDENTIFICATION OF STAGGERING AND OPENING STOP PLATE.

- Give the step command (A) and release, the leaf (1) will open. When it reaches the point at which one also wishes to open leaf (2) (opening staggering) give the step command (A) and release: leaf (2) will open. The two leaves continue to open slowly.
- When they have both reached the opening stop plate micros both red LEDs light.

#### PHASE 3

IDENTIFICATION OF CLOSURE STAGGERING AND STOP PLATE

- Give and release the step command (A): leaf (2) will close. When it reaches the point at which one also wishes to close leaf (1) (closure staggering) give and release the step command (A): leaf (2) will close. The leaves now both move at a normal speed when closing.
- On reaching the closure stop plate micros, the green LEDs flash and the red LEDs remain lit.

**The automation is now programmed.** The automation is now in semi-automatic mode by default.

If you are dissatisfied with the result obtained, **reset the control unit** and repeat procedure from start.

## RESETTING THE CONTROL UNIT

- Switch off the system's power supply.
- Press (⊖) and switch on the system's power supply until all four LEDs light.



### 3 ADJUSTMENTS

#### 3.1.1 Card initialisation

All the values previously stored on the card are erased and the automation is defined.

##### OPERATORS WITHOUT ELECTRIC STOP SWITCHES

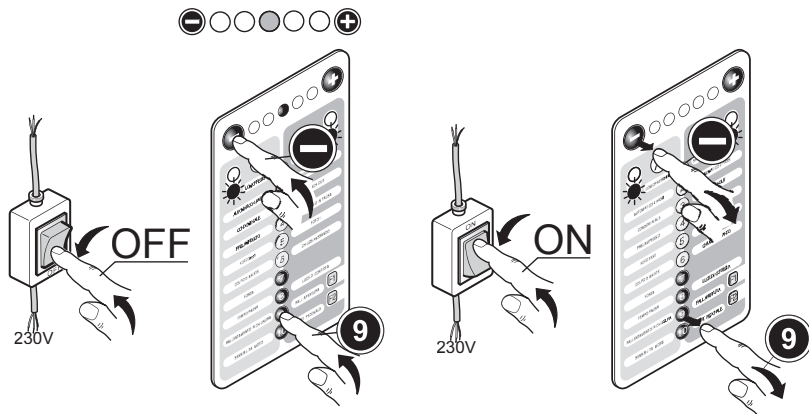

- Switch off power voltage.
- Simultaneously press and hold down **-** and **9** switch the power supply back on.
- After a few seconds the led will light **-○○○○○+**:
- Release keys **-** and **9**, the two red LEDs will now flash.

##### OPERATORS WITH ELECTRIC STOP SWITCHES

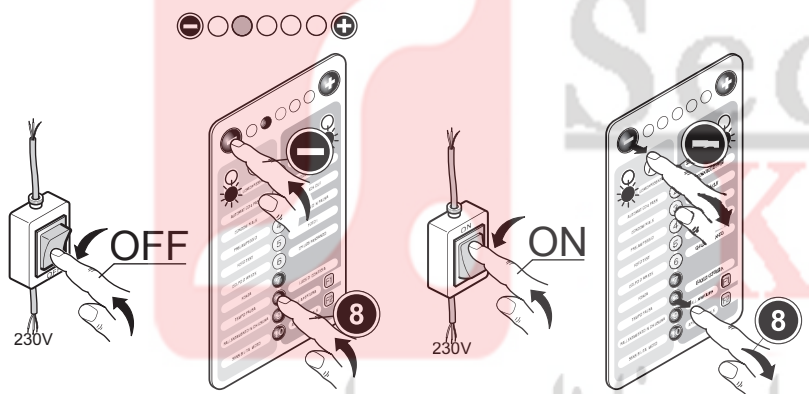

- Switch off power voltage.
- Simultaneously press and hold down **-** and **8** switch the power supply back on.
- After a few seconds the led will light: **-○○○○○+**.
- Release keys **-** and **8**, the two red LEDs will now flash.

#### 3.1.2 Resetting travel and functions

The travel, function modes and functions set are erased.

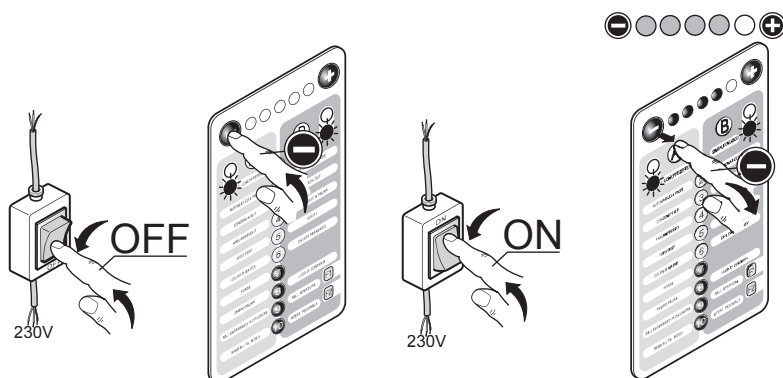

- Switch off power voltage.
- Press **-** hold it down and simultaneously switch the power supply back on.
- After a few seconds the LEDs will light: **-○○○○○+**.
- Release **-**, the two red LEDs will now flash.

### 3.1.3 Resetting the travel

The travel values and function modes are erased; the previously set function values remain.

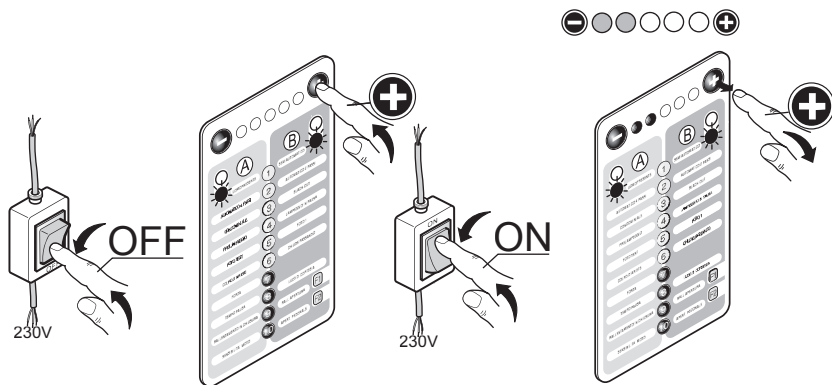

- Switch off power voltage.
- Press and hold down **+** and simultaneously switch the power supply back on.
- After a few seconds the LEDs will light: .
- Release **+**, the two red LEDs will now flash.



## 3.2 Function modes

5 different selectable function modes are envisaged: **DEAD MAN**, **SEMI-AUTOMATIC**, **2-STEP AUTOMATIC**, **4-STEP AUTOMATIC** and **CONDOMINIUM**. The selection of one mode excludes the others.

### 3.2.1 Dead man

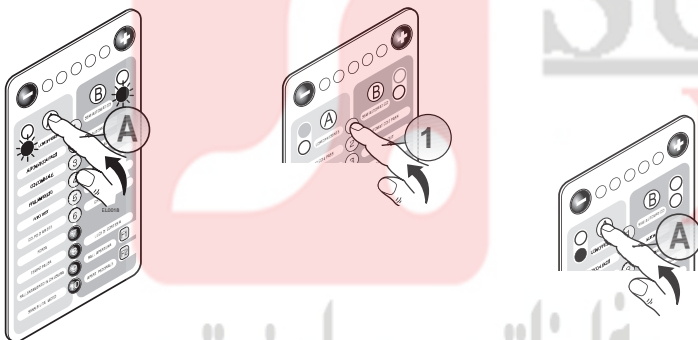
In this mode, gate movement only takes place if the 'step' key is held down (remote control, selector) and it stops when the key is released.



- Press **A** followed by **DEAD MAN** **1**:  
 if green LED (**SX**) is lit:  mode enabled,  
 if red LED (**SX**) is lit:  press **A** to enable.

### 3.2.2 Semi-automatic

**Automatic re-closure is not enabled.**

In this mode, by pressing the 'step' key on the remote control the gate changes its motion according to the sequence 1 – **OPEN** 2 – **STOP** 3 – **CLOSE** 4 – **STOP**; for example, if the gate is opening and one selects the step command on the remote control, the gate stops; conversely, if the gate is closed, when the command is given it opens.

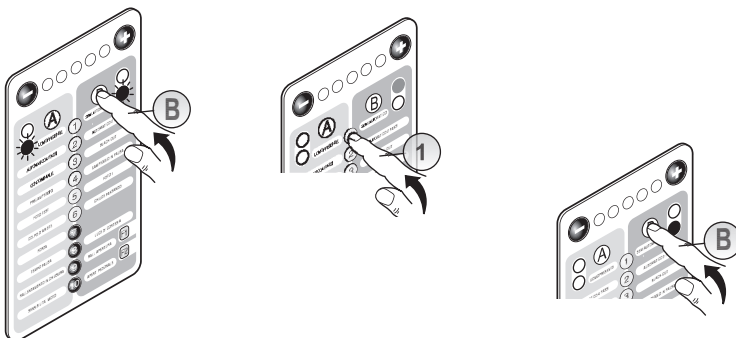

- Press **B** followed by **1 SEMI-AUTOMATIC**:  
 if green LED (**DX**) is lit:  mode enabled,  
 if red LED (**DX**) is lit:  press **B** to enable.

**OPEN » STOP » CLOSE » STOP**



### 3.2.3 2-step automatic

#### Automatic closure is enabled.

In this mode, by pressing the 'step' key on the remote control the gate changes its motion according to the sequence 1 – OPEN 2 CLOSE; for example, if the gate is opening and one selects the step command on the remote control, the gate stops and starts to close; conversely, if the gate is closed, when the step command is given it opens.

The gate closes automatically after the period set in the PAUSE TIME function.

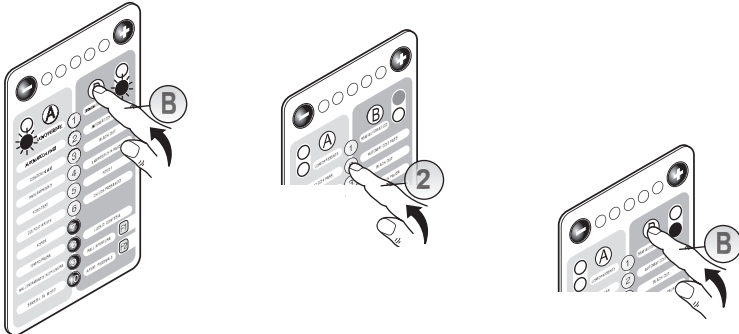

OPEN » CLOSE

Press **B** followed by **2** 2-STEP AUTOMATIC:  
if green LED (**DX**) is lit: ● mode enabled,  
if red LED (**DX**) is lit: ● press **B** to enable.

### 3.2.4 4-step automatic

#### Automatic closure is enabled.

In this mode, by pressing the 'step' key on the remote control the gate changes its motion according to the sequence 1 – OPEN 2 – PAUSE 3 – CLOSE 4 – PAUSE; for example, if the gate is opening and one selects the step command on the remote control, the gate pauses; conversely if the gate is closed, when the command is given it opens.

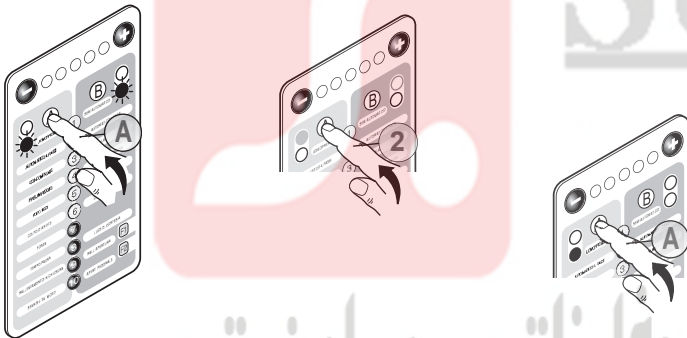

OPEN » PAUSE » CLOSE » PAUSE

Press **A** followed by 4-STEP AUTOMATIC **2**:  
if green LED (**SX**) is lit: ● mode enabled,  
if red LED (**SX**) is lit: ● press **A** to enable.

### 3.2.5 Condominium

#### Automatic closure is enabled.

The gate closes automatically after the period set in the PAUSE TIME function.

The 'step' command only works as an opening command. The CLOSE command is only enabled when the gate is fully open.

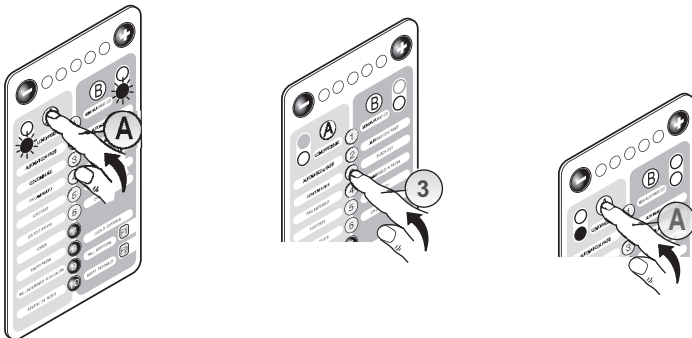

OPEN

To set press **A** and then CONDOMINIUM **3**:  
if green LED (**SX**) is lit: ● mode enabled,  
if red LED (**SX**) is lit: ● press **A** to enable.

### 3.3 Functions

#### 3.3.1 Blackout

The **RG UNI R** card reacts differently to temporary power failure depending on whether the leaf is open, closed or in an intermediate position:

Blackout NOT ACTIVATED:

- Leaf closed: the operator reverts to normal operation.
- Leaf open: after receiving two consecutive commands from the user the operator reverts to normal operation.
- Leaf in intermediate position: the automation remains immobile, when the first command is given, it opens slowly, when the leaf is fully open, it reverts to normal operation.

Blackout ACTIVATED:

- When the power supply is switched back on, in a mode that envisages automatic closure, the operator waits a fixed interval of 30 seconds and opens slowly.
- When the leaf is fully open, the operator reverts to normal operation.

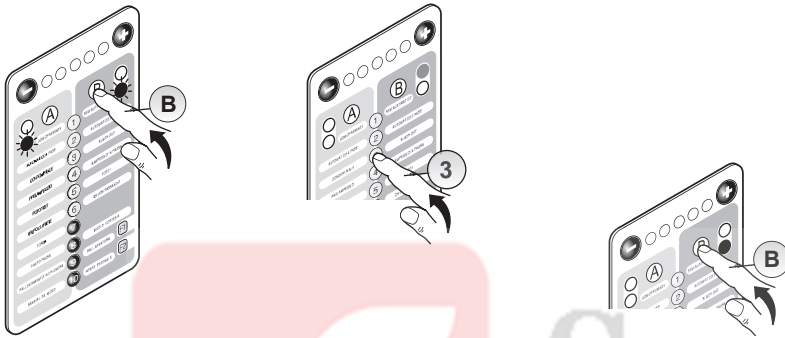

Press **B** and then **3** **BLACKOUT**:  
if green LED (**DX**) is lit: ● mode enabled,  
if red LED (**DX**) is lit: ● not enabled, press **B** to enable.

#### 3.3.2 Pre-flashing

This function enables 4-second pre-flashing by the flashing light before starting the closure or opening motion.

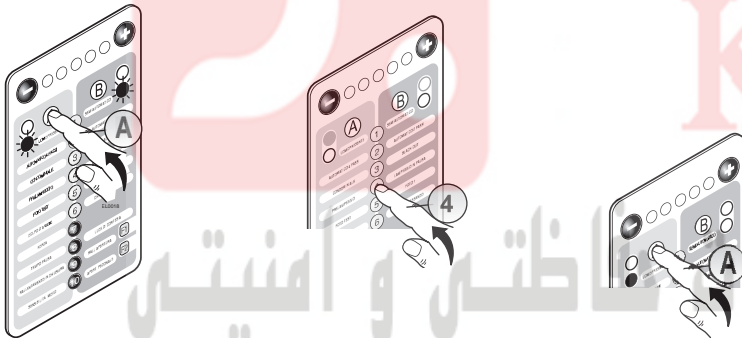

To enable press **A** followed by **PRE-FLASHING** **4**:  
if green LED (**SX**) is lit: ● mode enabled,  
if red LED (**SX**) is lit: ● mode not enabled, press **A** to enable.

#### 3.3.3 Flashing in pause

This function enables the operation of the flashing light during the pause before starting the automatic closure cycle.

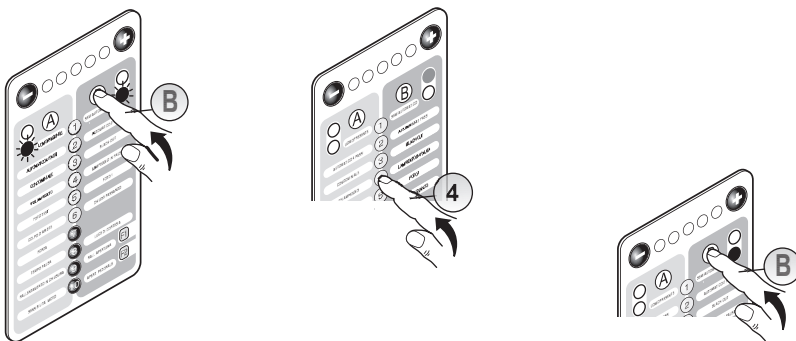

Press **B** followed by **4** **FLASHING IN PAUSE**:  
if green LED (**DX**) is lit: ● mode enabled,  
if red LED (**DX**) is lit: ● not enabled, press **B** to enable.

#### 3.3.4 PHOTO TEST

Do not use this function.



### 3.3.5 PHOTO 1

This function makes it possible to set for the inputs to the terminals 6 - 7 and 6 – 11 one of the following functions: **PHOTO, PHOTO 1, PHOTO 2, STOP AND PAUSE.**

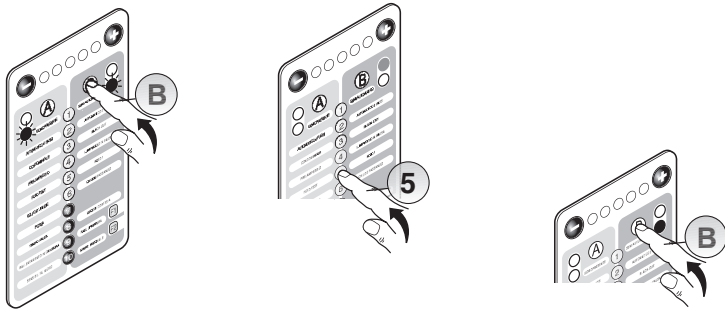

Press **(B)** followed by **(5)** **PHOTO 1**:  
 if green LED (**DX**) is lit: ● programming outputs 6-7.  
 if red LED (**DX**) is lit: ● programming outputs 6-11.

Press **(B)** to reverse terminal programming.  
 Having selected the input, press **(-)** or **(+)** to choose the function, referring to the lighting of the horizontal LEDs according to the following table:

LED	FUNCTION
● ○ ○ ○ ○ ○ ●	<b>PHOTO</b>
● ○ ○ ○ ○ ○ ●	<b>PHOTO1</b>
● ○ ○ ○ ○ ○ ●	<b>PHOTO2</b>
● ○ ○ ○ ○ ○ ●	<b>STOP</b>
● ○ ○ ○ ○ ○ ●	<b>PAUSE</b>

### 3.3.6 Close after photo

This function activates the automatic closure of the gate after the beam of the photocell programmed as PHOTO has been crossed; if the gate is opening it continues the opening motion and only closes again after total opening.

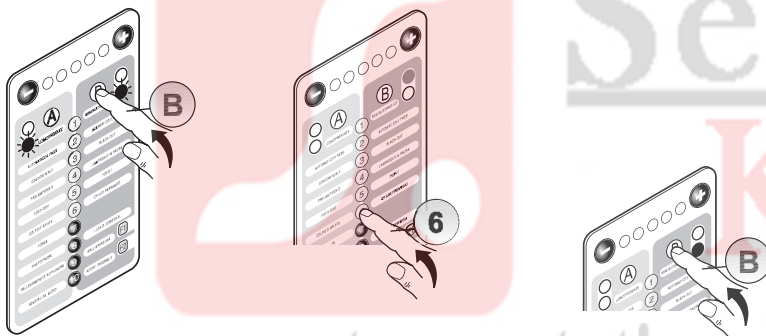

Press **(B)** followed by **(6)** **CLOSE AFTER PHOTO**:  
 if green LED (**DX**) is lit: ● mode enabled,  
 if red LED (**DX**) is lit: ● not enabled, press **(B)** to enable.

LED	FUNCTION
● ○ ○ ○ ○ ○ ●	<b>PHOTO</b>
● ○ ○ ○ ○ ○ ●	<b>PHOTO1</b>
● ○ ○ ○ ○ ○ ●	<b>PHOTO2</b>
● ○ ○ ○ ○ ○ ●	<b>STOP</b>
● ○ ○ ○ ○ ○ ●	<b>PAUSE</b>

### 3.3.7 Opening ram blow

This function enables the electrolock and a closure overtravel.

The closure overtravel after the gate is closed helps lock the electrolock, and during opening it helps release.

The closure overtravel is used in closure even without the electrolock in order to keep the leaves well tightened.

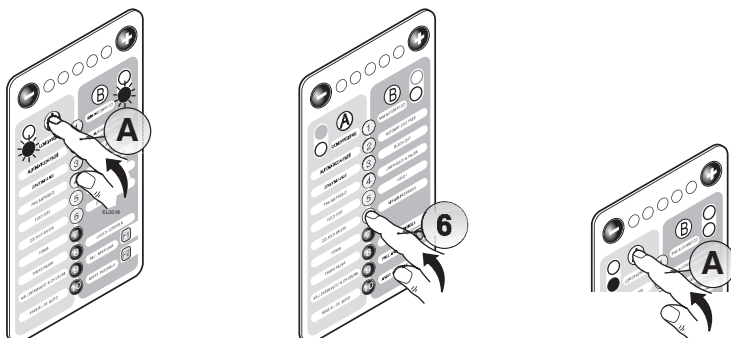

Press **(A)** followed by **OPENING RAM BLOW (6)** :  
 if green LED (**SX**) is lit: ● both the electrolock and overtravel are enabled.

if red LED (**SX**) is lit: ● the electrolock is disabled and the closure overtravel only can be activated.

Press **(A)** once again to enable/disable the electrolock.

The overtravel value can be regulated by pressing **(-)** and **(+)**.

LEDS ON	OVERTRAVEL VALUE
● ○ ○ ○ ○ ○ ●	<b>FUNCTION DISABLED</b>
● ○ ○ ○ ○ ○ ●	<b>MINIMUM</b>
● ○ ○ ○ ○ ○ ●	
● ○ ○ ○ ○ ○ ●	
● ○ ○ ○ ○ ○ ●	
● ○ ○ ○ ○ ○ ●	<b>MAXIMUM</b>



### 3.3.11 Deceleration in opening and closure.

These functions regulate the distance travelled by the gate in deceleration in the final stretches of opening and closure.

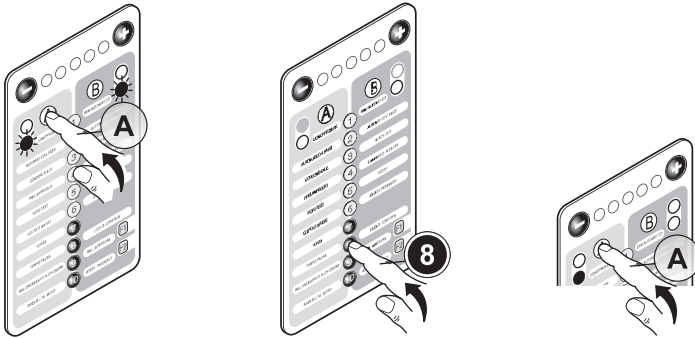

To set **DECELERATION IN CLOSURE** press **A** followed by **9**.

To set **DECELERATION IN OPENING** press **B** followed by **9**.

The various distances are set by pressing **-** and **+**.

LEDS ON	DECELERATION
○ ○ ○ ○ ○ ○ ○ ○ ○ ○	FUNCTION DISABLED
● ○ ○ ○ ○ ○ ○ ○ ○ ○	4% OF THE TRAVEL
● ● ○ ○ ○ ○ ○ ○ ○ ○	8% OF THE TRAVEL
● ● ● ○ ○ ○ ○ ○ ○ ○	12% OF THE TRAVEL
● ● ● ● ○ ○ ○ ○ ○ ○	16% OF THE TRAVEL

### 3.3.12 Work time

This function makes it possible to alter the motor work time. The adjustment is made with the gate closed.

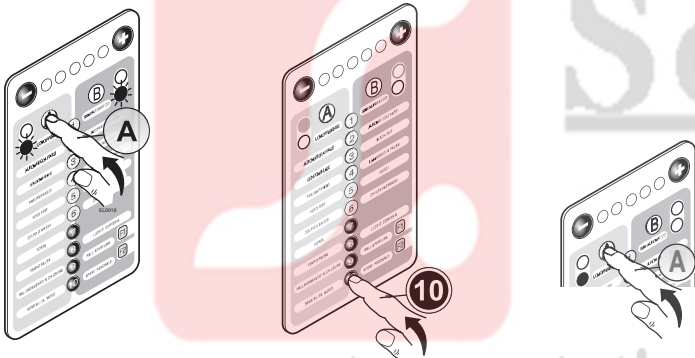

Press **A** and then **WORK TIME 10**:

if green LED (**SX**) is lit: ● adjustment motor 1 work time;

if red LED (**SX**) is lit: ● adjustment motor 2 work time.

The various values are set by pressing **-** and **+**.

Press **A** to switch between motor 1 and motor 2.

LEDS ON	WORK TIME
○ ○ ○ ○ ○ ○ ○ ○ ○ ○	MINIMUM
● ○ ○ ○ ○ ○ ○ ○ ○ ○	
● ● ○ ○ ○ ○ ○ ○ ○ ○	
● ● ● ○ ○ ○ ○ ○ ○ ○	
● ● ● ● ○ ○ ○ ○ ○ ○	
● ● ● ● ● ○ ○ ○ ○ ○	MAXIMUM

### 3.3.13 Pedestrian opening

Pedestrian opening is characterised by the opening of leaf 1.

This function regulates the amplitude of partial leaf opening associated to the pedestrian command.

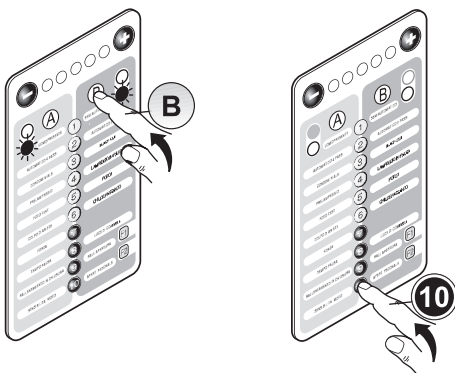

Press **B** followed by **10 PEDESTRIAN OPENING**:

The various values are set by pressing **-** and **+**.

LEDS ON	OPENING AMPLITUDE
○ ○ ○ ○ ○ ○ ○ ○ ○ ○	FUNCTION DISABLED
● ○ ○ ○ ○ ○ ○ ○ ○ ○	20 % OF THE TRAVEL
● ● ○ ○ ○ ○ ○ ○ ○ ○	40 % OF THE TRAVEL
● ● ● ○ ○ ○ ○ ○ ○ ○	60% OF THE TRAVEL
● ● ● ● ○ ○ ○ ○ ○ ○	80% OF THE TRAVEL
● ● ● ● ● ○ ○ ○ ○ ○	100% OF THE TRAVEL

## 3.4 Fuses

### 3.4.1 Frontal fuses

The frontal fuse is the fuse on the primary 230 volt power supply, and provides protection against the overload on the auto-transformer, external light circuits and operator.

Technical features: miniature fuse 5x20 T3,15A, IEC 60127 or EN 60127 certified.

If, despite being powered, the automation does not work, it is necessary to check the operator control unit's frontal fuse. This operation must be performed by a PROFESSIONAL FITTER.

Before replacing the fuse, it is essential to discover the reasons that cause it to blow: only then can the new fuse be placed in the fuse clip.

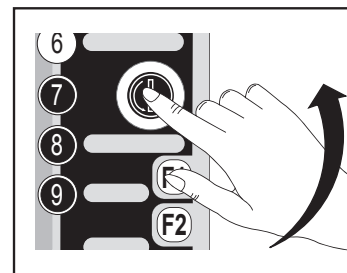

- Disconnect the electric power supply line.
- Press and simultaneously rotate the fuse clip towards the left.
- Remove the fuse and replace with a new one.
- Insert the clip on the fuse and relock by pressing and rotating towards the right.

The fuse must be IEC 60127 or EN 60127 certified

### 3.4.2 Card fuses

There is an internal fuse applied to the card: F1, for protecting the electronic board's power supply.

- Technical features F1: miniature fuse 5x20 T1,2A, IEC 60127 or EN 60127 certified.

**N.B. no intervention is authorised on the two card fuses.**

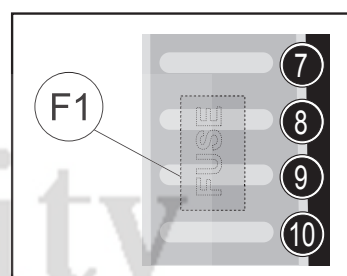

## 3.5 Preset functions F1 & F2

It is possible to select two standard function parameter settings. To enable them

- Press **B**.
- Press **F1** or **F2**.

Function	● GREEN LED ON		● RED LED ON	
	Default parameters	F1	F2	
DEAD MAN ①	●	●	●	
SEMI-AUTOMATIC ①	●	●	●	
4-STEP AUTOMATIC ②	●	●	●	
2-STEP AUTOMATIC ②	●	●	●	
CONDOMINIUM ③	●	●	●	
BLACKOUT ③	●	●	●	
PRE-FLASHING ④	●	●	●	
FLASHING IN PAUSE ④	●	●	●	
FOTO 1 ⑤	●	●	●	
OPENING RAM BLOW ⑥	●	●	●	
CLOSE AFTER PHOTO ⑥	●	●	●	
PAUSE TIME ⑧	●	●	●	
COURTESY LIGHT ⑧	●	●	●	
DECELERATION ON CLOSURE ⑨	●	●	●	
DECELERATION ON OPENING ⑨	●	●	●	
PEDESTRIAN OPENING ⑩	●	●	●	

The **FORCE** ⑦ function is not altered by the loading of the parameters **F1** and **F2**.

Function	Default parameters
FORCE ⑦	●





## 4 TROUBLESHOOTING

This chapter describes the most frequently encountered problems with the solutions for resolving them. In certain cases, it is explicitly envisaged that operations be performed by a professional fitter: these indications must be followed in order to avoid exposing oneself to serious risks.

### 4.1 Malfunctions indicated on the control unit

The malfunctions detected by the control unit are indicated through the lighting of the LEDs on the display  according to precise combinations.

The control unit also indicates the presence of a fault on the exterior through the flashing lamp: three flashes and a pause, if the motor is in motion.

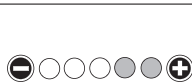
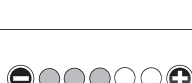
SIGNAL	MALFUNCTION	ACTION	POSSIBLE SOLUTION
	Closure stop plate	The control intervenes blocking the operator and switching it to dead man mode (persistent commands) and at reduced speed.	Try to perform a complete two-way travel (at reduced speed and with persistent commands). If the problem persists or arises frequently it is necessary to call the assistance service.
	Opening stop plate		
	Photocells	The check intervenes keeping the system in stop conditions.	Check the phototest setting and try to give another command to repeat the phototest. If the problem persists or arises frequently it is necessary to call the assistance service.
	Individual fault	The control intervenes by passing the system to the operation condition with dead man command and reduced speeds.	In this situation release the automation and call technical assistance.

**N.B. if the problems persist it is absolutely necessary to call the assistance service.**

## 5 AUTOMATION USE

### 5.1 Flashing light functions

The flashing light is a safety device used to indicate at a distance that the gate is moving. The light signals emitted by the flashing light are not always the same and depend on the movement (opening or closure) that the gate is performing.

The flashing light is also used by the automation's control unit to indicate a malfunction. In this case, the light signals emitted by the flashing light are different from those emitted during normal function.

The flashing light has three flashing modes:

1. slow for the gate opening phase;
2. fast (flashing times halved) during closure;
3. special flashing characterised by three flashes and a pause to signal a malfunction state.

### 5.2 Automation malfunction

The automation indicates the presence of a malfunction on the exterior by means of a flashing light (three flashes and a pause); if the problem is not a serious one, the user may resolve it as follows:

- a) keep the movement command pressed down (radio control or selector key);
- b) if the gate moves at reduced speed, perform an opening travel and take the gate to closure by continuing to hold the command key down;
- c) Switch the power supply off and back on again.
- d) Upon remote control command the automation is in normal function.

**ATTENTION: if the problem persists or arises frequently it is necessary to call the assistance service.**

In this case switch off the electricity supply to the automation. Do not attempt "amateur" repairs. Use the gate manually after releasing the actuator.

## 6 GENERAL INFORMATION

It is strictly forbidden to copy or reproduce this instruction manual without written permission to do so and subsequent verification by **LIFE home integration**. Translation into other languages of all or part of the manual is strictly forbidden without previous written authorisation from and subsequent verification by **LIFE home integration**. All rights on this document are reserved.

**LIFE home integration** will not accept responsibility for damage or malfunctions caused by incorrect installation or improper use of products and Users are therefore recommended to read this manual carefully.

**LIFE home integration** will not accept responsibility for damage or malfunctions caused by the use of the automation together with the devices of other manufacturers; such action will render the warranty void.

**LIFE home integration** will not accept responsibility for damage or injury caused by non-compliance with the installation, set up, maintenance and use indications contained in this manual and the safety instructions described in the SAFETY INSTRUCTIONS AND WARNINGS chapter.

With the aim of improving its products, **LIFE home integration** reserves the right to bring about alterations to them at any time, without giving prior notice. This document conforms to the state of the automation at which it is provided when released for sale.

## 6.1 INFORMATION ON THE MANUFACTURER

LIFE home integration is the manufacturer of the **GE UNI R** control unit (referred to for short as "control unit") and the owner of all rights concerning this document. The Manufacturer's information as required by Machinery Directive 98/37/EC is given below:

• Manufacturer:	LIFE home integration
• Address:	Via I Maggio, 37 – 31043 FONTANELLE (TV) Italy
• Telephone:	+ 39 0422 809 254
• Fax:	+ 39 0422 809 250
• http:	www.homelife.it
• e-mail:	info@homelife.it

The identity plate bearing the information on the Manufacturer is fixed to the control unit. The plate specifies the type and date (month/year) of manufacture of the product.

For further information on technical and/or commercial issues and technician call-out and spares requests, Clients may contact the Manufacturer or area representative from which the product was purchased.

## 6.2 INTENDED USE

- The **GE UNI R** control unit has been exclusively designed to command 2 electromechanical operators with 230 Vac power supply destined to motorising 'residential' type two-leaf swinging gates. Any usage differing from that described above is forbidden.
- Any usage differing from that described above is forbidden.
- The operator may not be installed or used in potentially explosive environments.
- Motorised gates must conform to current European standards and Directives, including EN 12604 and EN 12605.
- The operator may only be used when in perfect working order and in compliance with the intended use, in the awareness of safety and hazard conditions and in compliance with the instructions for installation and use.
- Any dysfunctions that may pose threats to safety must be eliminated immediately.
- The gate must be stable, properly hung and resistant to flexion (it must not bend during opening and closure movements).
- The operator cannot compensate for faulty or incorrectly hung gates. The operator may not be used in environments prone to flooding.
- Do not use the operator in environmental conditions characterised by harsh atmospheric agents (e.g. salty air).

# 7 GENERAL SAFETY INSTRUCTIONS AND WARNINGS

## 7.1 General instructions and warnings

- This manual is designed for use by **PROFESSIONAL FITTERS** only. Installation of the control unit requires practical and theoretical knowledge of mechanics, electrics and electronics as well as current sector legislation and regulations.
- Once the control unit has been installed, it is forbidden for users to perform any operation on the control unit even following the instructions in this manual, which, as mentioned previously, are intended for use by qualified personnel only.
- Fitters must operate in compliance with the following: law 46/90, directive 98/37/EC, 73/23/EEC, 89/336/EEC and subsequent amendments, and must also make constant reference to harmonised standards EN 12453 and EN 12445.
- The indications given in this manual must always be observed when installing, connecting, adjusting, testing and setting the control unit. The Manufacturer will not accept responsibility for damage or injury caused by non-compliance with the safety indications given in this manual.
  - The Manufacturer declines all responsibility for damage and faults to the control unit caused by non-observance of the instructions contained in this manual.
  - Keep this manual in a safe and easily accessible place so that it can be consulted rapidly when necessary.
  - Keep this manual in a safe and easily accessible place so that it can be consulted rapidly when necessary.
  - During installation, connection, trial run and usage of the control unit, observe all applicable accident prevention and safety regulations.
  - In the interests of safety and optimal functioning of the control unit, only use original spares, accessories, devices and fastening apparatus.
  - Do not perform alterations on any control unit device or component. This type of operation may cause malfunctions. The Manufacturer declines all responsibility for damage caused by products that have been modified.
  - Should liquids penetrate inside the control unit, disconnect the electricity supply and contact the Manufacturer's Assistance Service immediately; use of the control unit in such conditions may cause hazard situations.
  - In the event of long periods of inactivity, in order to prevent the leakage of harmful substances from the battery (optional), it should be removed, stored in a dry place and recharged periodically.
  - In the case of faults or problems that cannot be resolved using the information contained in this manual, contact the Manufacturer's assistance service.

## 7.2 Storage instructions and warnings

- The manufacturer declines all responsibility for damage and faults to control unit functioning caused by non-compliance with the storage instructions given below.
  - The control unit must be stored in closed, dry places, at room temperatures of between -20 and +70°C and raised off the ground.
- Keep the control unit away from sources of heat and naked flames, which could damage it and cause malfunctions, fires or hazard situations.

# 8 INSTALLATION

**ATTENTION: Important safety instructions. Follow all instructions carefully, incorrect installation may cause serious injury.**

Before commencing installation we highly recommend reading the instructions and warnings contained in this manual carefully (see the **SAFETY INSTRUCTIONS AND WARNINGS** Chap) and observing the instructions it contains.

## 8.1 INSTRUCTIONS AND WARNINGS FOR INSTALLATION

- Before commencing installation read the **SAFETY INSTRUCTIONS AND WARNINGS** chapter carefully.
- The **PROFESSIONAL FITTER** who installs the control unit is responsible for performing risk analysis and regulating the automation's safety devices consequentially.
- Before commencing installation, check whether further devices or materials are needed to complete the automation in order to suit the specific situation in which it will be used.
- The Fitter must check that the temperature range declared on the operator (see Technical Data Chap.) is suited to the place in which the device is installed.
- The operator cannot be fitted on gates with separate pedestrian access, unless operator function is prevented when the door is open.
- Before installing the operator, ensure that the gate is in good mechanical conditions, correctly balanced and that it opens and closes correctly.
- Ensure that there is no risk of entrapment between the open gate and surrounding parts following the opening movement.
- Any normally open/off buttons installed for the activation of the operator must be positioned so that they are within view of the gate but distant from moving parts. Unless said commands operate using keys, they must be positioned at a minimum height of 1.5m and not accessible to unauthorised persons.
- Once the automation has been installed, ensure that it is correctly adjusted and that the protection systems and release work properly.
- It is strictly forbidden to motorise a gate that is not already efficient and secure as the automation cannot resolve faults caused by incorrect installation or poor maintenance of the gate.
- During installation, make constant reference to harmonised standards EN 12453 and EN 12445.
- Ensure that the individual devices to be installed are compatible with **GE UNI R** control unit, paying careful attention to the points raised in the **TECHNICAL DATA** chapter. Do not proceed if even just one device is unsuitable for the intended use.
- Ensure that the place of installation of the central unit is not prone to flooding, does not contain sources of heat or naked flames, fires or hazard situations in general.
- During installation, protect control unit components in order to prevent liquids (e.g. rain) and/or foreign bodies (earth, gravel, etc) penetrating inside.
- Connect the control unit to a power supply line created in compliance with current regulations and earthed and fitted with a power supply sectioning switch.
- The control unit may be fitted with a pair of buffer batteries (optional); the installation, maintenance and replacement of buffer batteries must be performed by a **PROFESSIONAL FITTER**.
- Wrapping materials must be disposed of in compliance with local regulations.
- Wear protective goggles when making holes for clamping.
- In the event of work at heights of over 2m from the ground, for example for the installation of the indicator lamp or aerial, fitters must be equipped with ladders, safety harnesses, protective helmet, and all other equipment required by law and the standards governing this kind of work. Refer to Directive 89/655/EEC amended by 2001/45/EC.



## 9 TESTING AND TRIAL RUN

- The testing and trial run must be performed by a **COMPETENT PERSON** supervised and aided by a **PROFESSIONAL FITTER**. It is the responsibility of the person who tests and sets up the automation (of which the control unit is a part) to perform the checks required in accordance with the risks existing and to check conformity with the relevant legislation and standards, in particular with **EN standard 12445**, which governs the methods for performing trials on gate automations and **EN standard 12453** that specifies the performance requisites concerning safety of use.
- The testing and trial run are the most essential phases of installation for guaranteeing maximum operating safety.
- The checks and procedures for testing may also be used for routine checks on the automation and its devices.
- The automation may only be tested if a non-hazardous force tolerance has been set. Force tolerance must be adjusted to a minimum value so as to exclude the danger of injury during closure.
- Adjust the maximum force in line with **EN standard 12445**.
- Never touch the gate or moving parts when they are in motion.
- Remain at a safe distance when the gate is in motion: only pass when the gate is completely open and immobile.
- In the event of malfunctions (noisiness, jerky movements, etc.) suspend the use of the automation immediately: failure to observe this rule may entail serious hazards, risks of accidents and/or serious damage to the gate and the automation.
- Always remember that the following residual risks exist when the gate is in movement:
  - a) impact and crushing against the main closure edge (against the single leaf or between the two leaves);
  - b) impact and crushing in the opening area;
  - c) shearing between the moving and the fixed guides and support during movement;
  - d) mechanical risks caused by movement.

### 9.1 Testing

During testing, ensure that the measurement of the gate's impact force has been performed in accordance with **EN standards 12445 and 12453**.

- Check that the indications given in the **SAFETY INSTRUCTIONS AND WARNINGS** and **INSTRUCTIONS AND INDICATIONS FOR INSTALLATION** chapters have been carefully observed.
- Ensure that the automation is correctly adjusted and that the protection and release systems are in good working order.
- For each component installed follow the procedure described in the respective instruction manuals.
- Using the key selector or the radio control perform gate opening and closure tests and ensure that each movement of the gate corresponds to the control unit settings. Perform as many checks as necessary to be certain of perfect operation.
- Ensure the correct operation of the leds on the keyboard of the control unit
- In particular, for photocell checks, check that there is no interference with other devices. Pass a cylindrical tube with a diameter of 5cm and a length of approximately 30 cm through the optic axis that connects the two photocells. Perform this check firstly close to the transmitter and then close to the receiver and lastly halfway between the two.
- In all three cases, the device must intervene by passing from the active state to the alarm state and vice versa, thus causing the action set on the control unit: for example, during a closure manoeuvre it must cause inversion of movement.
- Perform the photocell operation test required in compliance with **EN standard 12445 p. 4.1.1.6**. The results must satisfy **EN standard 12453 p. 5.1.1.6**.

**ATTENTION:** once the automation has been tested, the parameters set must not be altered. If further adjustments (e.g. alterations to the voltage value) are made, all the checks required for testing and compliance with **EN standard 12445** must be repeated.

### 9.2 First Usage

The automation may only be used for the first time once all the checks described in the **TESTING** chapter have been performed successfully. The automation may not be used in precarious or temporary conditions.

- a) Compile a technical file for the automation, which must include at least:
  - a general mechanical and electrical diagram,
  - risk analysis and solutions adopted for eliminating or reducing risks,
  - manuals of the individual components,
  - list of the components used,
  - instructions for use and warnings concerning use by the owner,
  - system maintenance record
  - declaration of the system's CE conformity
- b) Fix a CE marking plate to the gate, bearing at least the following information:
  - Name and address of the party responsible for installation and testing;
  - Type of automation;
  - Model;
  - Registration number;
  - Year of installation
  - CE mark
- c) Fill in the declaration of conformity and give it to the owner of the automation.
- d) Compile the guide with the instruction manual (**EN 12635 p. 5.3 and 5.4**) and give it to the owner of the automation.
- e) Compile the maintenance and improvement log (**EN 12635 p.5.3**) and give it to the owner of the automation.
- f) Compile the guide containing the instructions for maintenance that provides instructions concerning the maintenance of all automation devices (**EN 12635 p. 5.3 and 5.5**) and give it to the owner of the automation.
- g) Before the first use of the automation, the owner must have been given adequate information concerning hazards and residual risks.

## 10 SAFETY INSTRUCTIONS AND WARNINGS FOR USE

### 10.1 Indications and warnings for use

- It is the fitter's duty to perform risk analysis and inform the user/owner of any existing residual risks. Any residual risk detected must be recorded in writing in the operator manual.
  - The following residual risks are usually present in moving gates: impact and crushing against the main closure surface (of the single leaf or between the two leaves); impact and crushing in the opening area; crushing between the mobile and fixed guide and support parts during movement; mechanical risks caused by movement.
  - The Manufacturer will not accept responsibility for damage or injury caused by the non-observance of the information on use contained in this manual, and the failure to observe the safety indications given below.
  - The Manufacturer declines responsibility for damage and malfunctions caused by non-compliance with the instructions for use.
  - Keep this manual in a safe, easily accessible place, so that it can be consulted rapidly when necessary
  - Before activating the gate ensure that all persons are at a safe distance.
  - Never touch the gate or moving parts when in motion.
  - Remain at a safe distance when the gate is in motion: only pass when the gate is completely open and immobile.
  - Do not allow children to play with gate controls; do not leave radio controls or other control devices within children's reach.
  - Prevent children from playing or standing in the vicinity of the gate or the control organs (radio controls), the same precautions should be adopted for disabled persons and animals.
  - In the event of malfunctions (noisiness, jerky movements, etc.) suspend the use of the automation immediately: failure to observe this rule may entail serious hazards, risks of accidents and/or serious damage to the gate and the automation. Contact a **PROFESSIONAL FITTER** and in the meantime use the gate manually by disconnecting the operator (see the **OPERATOR/ACTUATOR RELEASE** chapter).
  - In order to maintain the automation in efficient conditions, ensure that the operations indicated in the **MAINTENANCE** chapter are performed at the frequency indicated by a **PROFESSIONAL FITTER**.
  - Examine the installation frequently in order to check that there are no signs of mechanical unbalance, wear and damage to the wires and assembled parts: do not use the operator until the necessary repairs or adjustments have been made.
  - Should liquids penetrate inside the control unit, disconnect the power supply immediately and contact the Manufacturer's Assistance Service; the use of the automation in such conditions may cause hazard situations. The automation may not be used in these conditions, even with buffer batteries (optional).
- If a problem arises that cannot be resolved using the information contained in this manual, contact the Manufacturer's assistance service.

## 11 MAINTENANCE

### 11.1 Maintenance instructions and warnings

- Once the automation has been tested, the parameters set must not be altered. If further adjustments (e.g. alterations to the voltage value) are made, ALL THE CHECKS REQUIRED FOR TESTING AND COMPLIANCE WITH STANDARDS MUST BE REPEATED.
- The Manufacturer declines responsibility for damage or injury caused by non-compliance with the information provided in this manual and the safety instructions provided below.
- The Manufacturer declines all responsibility for damage and malfunctions deriving from non-compliance with the maintenance instructions.
- In order to keep the operator efficient and safe, follow the cleaning, checking and routine maintenance procedures as described in this manual. This is the owner's duty.
- Any checking, maintenance or repair work must be conducted by a PROFESSIONAL FITTER
- Always switch off the electricity supply in the event of malfunctions, breakdowns and before any other operations in order to avoid the gate from being activated.
- Always disconnect the operator's power supply before performing any maintenance or cleaning operation.
- The owner is not authorised to remove the control unit cover as it contains live parts.
- If the power cable is damaged, it must be replaced by the Manufacturer or its technical Assistance service or in any case a person with a similar qualification in order to avoid risks.
- Use original spare parts, accessories and clamping material only.
- Do not perform technical or programming modifications on the control unit. Operations of this type may cause malfunctions and/or risk of accidents. The Manufacturer declines responsibility for damage deriving from modified products.
- In the event of intervention of automatic or fuse switches, before restoring function conditions identify and eliminate the fault. Request the intervention of a PROFESSIONAL FITTER.
- The disconnection and replacement of the pair of buffer batteries (optional) may be performed by a PROFESSIONAL FITTER only.
- If a fault that cannot be solved following the information contained in the present manual arises, contact the manufacturer's assistance service.
- All maintenance, repair or replacement of parts must be recorded in the maintenance log, which is SUPPLIED AND INITIALLY FILLED IN BY THE FITTER.

### 11.2 Routine maintenance

Every 6 months a PROFESSIONAL FITTER should repeat the series of tests described for automation testing (see INSTALLATION MANUAL – TESTING AND TRIAL RUN Chap. ).

## 12 DEMOLITION AND DISPOSAL

- The control unit is constructed using various materials, which implies the adoption of different disposal procedures. Refer to regulations in force in the country in which the automation is installed, especially with regard to the buffer batteries (if present).
- If present the batteries must be removed from the control unit prior to disposal. Disconnect the control unit from the electricity supply before removing batteries. Contact qualified firms for disposal.

**ATTENTION:** operator disconnection from the mains supply must be performed by a qualified electrician using suitable tools.

## 13 MANUFACTURER'S DECLARATION OF CONFORMITY

Declaration of conformity



under Directive 98/37/EC, appendix II, part B (Manufacturer's Declaration of CE Conformity).

LIFE home integration

Via 1 Maggio, 37

31043 FONTANELLE (TV) – Italy

declares that the following product:

GE UNI R control unit

satisfies the essential requisites established in the following directives:

- Low voltage directive 73/23/EEC and subsequent amendments,
- Electromagnetic compatibility directive 89/336/EEC and subsequent amendments,
- Radio and telecommunications equipment directive 1999/5/EC and subsequent amendments.

and satisfies the following standards:

- |                         |  |
|-------------------------|--|
| • EN 12445:2000         | Industrial, commercial and garage doors and gates – Safety in the usage of motorised doors – testing methods   |
| • EN 12453:             | Industrial, commercial and garage doors and gates – Safety in the usage of motorised doors - Requisites.   |
| • EN 60204-1:1997       | Machinery safety – Electric equipment of the machine – Part 1: general rules.  |
| • EN 60950              | Information technology equipment - Safety - Part 1: General requisites   |
| • ETSI EN 301489-3:2001 | Electromagnetic compatibility for radio equipment and appliances.  |
| • EN 300220-3:2000      | Radio equipment and systems – short band devices – Technical characteristics and testing methods for radio apparatus with a frequency of 25 to 1000 MHz and powers of up to 500mW. |

The Manufacturer also declares that it is not permitted for the abovementioned components to be used until such time as the system in which they are incorporated is declared conform to directive 98/37/EC.

Fontanelle \_\_\_\_\_

Name of Signor:  
Position:  
Signature:

Faustino Lucchetta  
Managing Director

